



*Tentative Agenda for Regular
Meeting of Town Council*

Monday, August 14, 2023 @ 7:00 PM

*55 Victoria Street
Kensington, PEI
C0B 1M0
Phone: (902) 836-3781
Fax: (902) 836-3741
Email: mail@kensington.ca
Web Site: www.kensington.ca*

*Please ensure all cell phones and other electronic devices are turned
off or placed on non-audible mode during the meeting.*

5.1 July 10, 2023 Regular Meeting

6.1 July 10, 2023 Regular Meeting

7.1 Chief Administrative Officer Report - *Nil*

7.2 Fire Department Report

7.3 Police Department Report

7.4 Development Permit Summary Report

7.5 Bills List – Town - *Nil*

7.6 Bills List - Water and Sewer Utility - *Nil*

7.7 Bills List – Capital - *Nil*

7.8 Consolidated Summary Income Statement - *Nil*

7.9 Credit Union Centre Report

7.10 Mayor's Report

- 7.11 Federation of Prince Edward Island Municipalities Report – Councillor Mann
- 7.12 Kensington and Area Chamber of Commerce Report – Councillor MacRae
- 7.13 2023 – 55 Plus Games Report – Deputy Mayor Spencer
- 7.14 Heart of PEI Committee – Mayor Caseley

8.1 _____

- 8.1.1 RFD2023- 37 – Credit Union Centre – Rural Growth Initiative (RGI) Funding Program
- 8.1.2 RFD2023- 38 – Guaranteed Basic Income Benefits for Prince Edward Island
- 8.1.3 RFD2023- 39 – 2023 Annual Sidewalk Maintenance

Nil

Mayor Rowan Caseley; Deputy Mayor Jeff Spencer
Councillors: Toombs, Gallant, Mann, MacRae, and Doucette

Chief Administrative Officer, Geoff Baker; Municipal Clerk,
Kim Caseley; Manager of Finance & Administration, Dellon
Paul

Marie Burge and Wayne Easter - Cooper Institute

Mayor Caseley called the meeting to order at 7:00 PM and welcomed Council members, staff, and visitors to the July meeting of Kensington Town Council. Mayor Caseley acknowledged that the land on which we gather is the traditional and unceded territory of the Mi'kmaq First Nation.

Moved by Councillor Gallant, seconded by Councillor Toombs to approve the tentative agenda for the July 10, 2023 regular meeting of Town Council. Unanimously carried.

Nil.

Marie Burge and Wayne Easter from the Cooper Institute made a presentation to Town Council on a Basic Income Guarantee Program.

Marie Burge and Wayne Easter excused themselves from the Council Chamber at 7:45 pm.

Moved by Councillor MacRae, seconded by Deputy Mayor Spencer to approve the minutes from June 12, 2023, regular meeting of Town Council. Unanimously carried.

Nil.

Moved by Councillor Doucette, seconded by Councillor Toombs to adopt the June 2023 CAO Report as prepared by CAO, Geoff Baker. Unanimously carried.

Moved by Councillor Doucette, seconded by Deputy Mayor Spencer to approve the May 2023 Fire Statistical report as prepared by Fire Chief, Rodney Hickey. Unanimously carried.

Moved by Councillor MacRae, seconded by Councillor Toombs to approve the May 2023 Police Statistical Report as prepared by Chief Sutherland. Unanimously carried.

Chief Sutherland excused himself from the Council Chamber at 7:49 pm.

Moved by Councillor Gallant, seconded by Deputy Mayor Spencer to approve the July 2023 Development Permit Summary Report as prepared by Municipal Clerk, Kim Caseley. Unanimously carried.

Town of Kensington Bills Report – Nil.

Water & Sewer Utility Bills Report – Nil.

Capital Expenditures Report – Nil.

Nil.

Moved by Deputy Mayor Spencer, seconded by Councillor Doucette to approve

the Credit Union Centre report for the month of May 2023. Unanimously carried.

Moved by Councillor Toombs, seconded by Councillor Gallant to approve the Mayor's report for the month of June 2023 as presented by Mayor Caseley. Unanimously carried.

Nil.

Nil.

The newly established "Ask Kensington" Facebook page is active and going well.

The KACC held a successful Car Rally, it was noted that additional volunteers will be required for next year.

The KACC Golf Tournament was a success and are hoping to keep its June schedule next year.

Councillor MacRae discussed a potential *Locks of Love* project at the Alysha Toombs Memorial Park.

Deputy Mayor Spencer confirmed that registration will open on July 12th.

Moved by Councillor Gallant, seconded by Councillor Toombs

THAT Kensington Town Council authorize staff to proceed with an expansion to the Credit Union Centre Parking Area, as per the quote from Curran and Briggs in the amount of \$168,833.00 plus HST, dated July 5, 2023.

4 for – 2 opposed (MacRae & Toombs) – Motion carried.

Moved by Deputy Mayor Spencer, seconded by Councillor Doucette

BE IT RESOLVED THAT Town Council direct the CAO to proceed with scheduling a public meeting to gather further information in the consideration of an application to amend the Town of Kensington Development Control Bylaw and Official Plan, to re-zone PID No. 685545 from its current Single Residential Zoning designation (R1) to a Low-Density Residential Zoning Designation (R2).

Unanimously carried.

Moved by Councillor Mann, seconded by Councillor Toombs

BE IT RESOLVED THAT Town Council approve the 2022/2023 Audited Financial Statements as prepared by Arsenault Best Cameron Ellis Chartered Accountants.

Unanimously carried.

Mayor Caseley confirmed that Committee of Council will not meet during the months of July & August.

Moved by Councillor Mann, seconded by Councillor Gallant to enter a Town of Kensington team in the 2023 Harvest Festival Golf Tournament in the amount of \$450.00.

Unanimously carried.

Councillor Toombs and Councillor Gallant inquired about the broken barricades at the property located at 88 Victoria Street (Hello Kitchen) and requested the area be cleaned up.

Councillor Gallant noted that some residents are cutting their grass onto the roads, creating a hazard for vehicles and pedestrians. It was requested that residents are provided with a notice when situations occur.

Councillor Gallant noted the unmaintained grass of the vacant lot located 105 Victoria Street and requested the property owner be required to have it regularly maintained.

Annual Report from the Kensington Senior Surfers Club

A thank you note from Jack McCarville, KISH 2023 Grad and recipient of the French 621 Academic Award sponsored by the Town of Kensington.

A thank you note from the PEI Humane Society for the recent donation in memory of Judy Cole.

A thank you note from the KISH 2023 Grads for supporting their Prom & Grad activities.

A letter on behalf of the International Wrongful Conviction Committee requesting that the Town of Kensington proclaim October 2, 2023, as “Wrongful Conviction Day”.

- Approved

The 2023 Annual Harvest Festival theme is “Celebrating our First Responders”. Councillor Toombs and Councillor Gallant noted that members of the community would like to see more booths available at the Harvest Festival activities.

Saturday, August 19 at 2:00 PM is the Annual Harvest Festival Parade. The float will be lined up by 1:00 PM for Council members available to attend.

Nil.

Moved by Councillor Toombs, seconded by Councillor MacRae to adjourn the meeting at 8:39 PM. Unanimously carried.

Geoff Baker,
CAO

Rowan Caseley,
Mayor

Kensington Fire Department
Occurrence Report 2023

Description	January	February	March	April	May	June	July	August	September	October	November	December	YTD total	% Total
Medical First Responder	3	1	2	4	3	5							18	26.47%
Motor Vehicle Accident	4	2	1	5	2	1							15	22.06%
Emergency Response - Fuel Spill, etc	0	0	0	0	0	0							0	0.00%
Fire Related														
Smoke Investigation	1	1	0	1	0	0							3	4%
Outside Fire - Brush, Grass, Utility Pole, etc.	0	0	1	4	2	0							7	10%
Structure Fire - House, Building, Vehicle, etc.	0	0	5	3	2	3							13	19%
Alarms	4	3	1	2	1	1							12	18%
Total Fire Related	5	4	7	10	5	4	0	0	0	0	0	0	35	
Total Incidents	12	7	10	19	10	10	0	0	0	0	0	0	68	
Mutual Aid Call Out													0	0%
Total Incidents (Including Mutual Aid Provided by KFD)	12	7	10	19	10	10	0	0	0	0	0	0	68	100%
Mutual Aid Call in														
Firefighter Attendance	12	12	15	15	12	12								13
Regular Monthly Training - No. of Firefighters	24	18	22	17	17	20								20
Training School/Association Meeting/Department Meeting	21	19	23	17	18	18								19
Call Area														
Kensington	1	3	4	2	4	2							16	23.53%
Malpeque CIC	3	1	1	7	2	3							17	25.00%
Zone's 1 to 5	8	3	5	10	4	5							35	51.47%
Other													0	0.00%

Kensington Fire Department June 2023 Fire Report

The Kensington Fire Department responded to 10 calls in June. Following is a breakdown of the calls:

Date	Call Details	Location	# Firefighters	# Trucks
June 12 13:32 pm	MFR	Malpeque	9	1
June 14 15:12 pm	Vehicle Fire	Emerald	18	3
June 18 07:56 am	Structure Fire	Irishtown Rd.	23	5
June 20 15:16 pm	MVC	New Annan	15	2
June 22 15:07 pm	Structure Fire	Freetown	14	3
June 22 16:34 pm	MFR	Indian River	8	1
June 24 10:21 am	MFR	Kensington	6	1
June 24 16:16 pm	Residential Fire Alarm	Norboro	11	2
June 25 20:29 pm	MFR	Sea View	11	1
June 30 07:14 am	MFR	Kensington	8	1

May 29 - June Association meeting held - 18 present.

June 6 - Several firefighters attended an equipment demonstration at Summerside Fire Hall.

June 20 - Training with 20 present.

Police Department Occurrence Report Summary 2023														
Description	Jan	Feb	Mar	Apr	May	Jun	Jul	Aug	Sep	Oct	Nov	Dec	YTD	% Total
911 Act	1	3	2	2		1							9	2.64%
Abandon Vehicle			1		1								2	0.59%
Abduction													0	0.00%
Alarms	3		3	3	2	5							16	4.69%
Animal Calls	2		2		1	1							6	1.76%
Arson													0	0.00%
Assault PO													0	0.00%
Assault with Weapon					1								1	0.29%
Assaults (Level 1)	2			2	3								7	2.05%
Assistance Calls	1	5	1	1	1	2							11	3.23%
Bank Runs	2												2	0.59%
Breach of Peace		1			4								5	1.47%
Breach of Recognizance													0	0.00%
Break and Enter (business)													0	0.00%
Break and Enter (other)													0	0.00%
Break and Enter (residence)	2												2	0.59%
Carry concealed weapon													0	0.00%
Child Pornography													0	0.00%
Child Welfare	1	1				1							3	0.88%
Coroner's Act				1	1								2	0.59%
Crime Prevention													0	0.00%
Criminal Harassment					1								1	0.29%
Dangerous Driving	2	3			2	2							9	2.64%
Disturbing the Peace	1				2								3	0.88%
Dog Act													0	0.00%
Driving while disqualified				1	1	2							4	1.17%
Drug Charges			1	1		1							3	0.88%
Excise Act													0	0.00%
Fail to Comply Probation		1											1	0.29%
Fail to comply undertaking	1		1		2								4	1.17%
Fail to remain at scene of accident													0	0.00%
Family Relations Act	5			1									6	1.76%
Fingerprints taken													0	0.00%

Police Department Occurrence Report Summary 2023														
Description	Jan	Feb	Mar	Apr	May	Jun	Jul	Aug	Sep	Oct	Nov	Dec	YTD	% Total
Fire Prevention Act			1	1	1								3	0.88%
Firearm Act			1										1	0.29%
Forcible confinement													0	0.00%
Fraud		1	2	2	2								7	2.05%
Funeral Escorts	2		2	1	2	2							9	2.64%
Harrassing Communication	1	1		2	1								5	1.47%
Impaired Driver		1		2									3	0.88%
Information Files	2	1		1	1	3							8	2.35%
Injury Accidents													0	0.00%
Liquor Offences													0	0.00%
Litter Act													0	0.00%
Lost and Found	3		1	3		2							9	2.64%
Luring Minors													0	0.00%
Mental Health Act	1			2	1								4	1.17%
Mischief	1	5			1	4							11	3.23%
Motor Vehicle Accidents	2	2	1	2		5							12	3.52%
Motor Vehicle Act	2	7	5	5	6	6							31	9.09%
Municipal Bylaws			3		2	1							6	1.76%
Off Road Vehicle Act					1								1	0.29%
Other Criminal Code			1			1							2	0.59%
Person Reported Missing	1												1	0.29%
Possession of restricted weapon													0	0.00%
Property Check	2		2		1	1							6	1.76%
Resist Arrest													0	0.00%
Roadside Suspensions													0	0.00%
Robbery													0	0.00%
Sexual Assaults / Interference	1												1	0.29%
STEP (Integrated Traffic Enforcement)													0	0.00%
Sudden Death													0	0.00%
Suspicious Persons / Vehicle	2	5	3	3	3	5							21	6.16%
Theft Of Motor Vehicle	2	1			1								4	1.17%
Theft Over \$5000													0	0.00%
Theft Under \$5000	3	8			1	4							16	4.69%

Police Report June2023

There were five alarm calls to report for this month.

June 9th @ 0203hrs – Shoe repair shop, member attended.

June 20th @ 0920hrs – Maritime harness racing, member attended.

June 23rd @ 0720hrs – Frosty treat, member attended.

June 24th @ 1618hrs- Liquor Store, member attended.

June 29th @ 0556hrs- Frosty treat, member attended.

Assistance files for the month consisted of:

Assist family members over dog dispute.

Assistance in keeping the peace while house guest leaves.

June 9 assist RCMP with Impaired operation file.

Year To Date Approved Development Permits Summary Report 2023

Development Permit Category	January	February	March	April	May	June	July	August	September	October	November	December	Total
Addition Industrial						1							1
Addition Residential Deck/Fence/Pools					1								1
New Industrial						2							2
New Multi-unit Family Dwelling				1									1
New Residential Accessory Structure				1			1						2
New Residential Deck/Fence/Pools					2	1							3
Renovation Commercial			2										2
Renovation Residential additions/alterations						1							1
Renovation Residential Deck/Fence/Pools					1								1
Renovation Single Family Dwelling		2	1										3
Total:		2	1										17

Total Estimated Construction Value
\$180,000.00
\$2,000.00
\$3,314,105.00
\$2,150,000.00
\$37,450.00
\$21,900.00
\$130,000.00
\$40,000.00
\$1,500.00
\$498,000.00
\$6,374,955.00

DEVELOPMENT PERMITS REPORT

For the period July 07, 2023 to August 11, 2023

Permit Number	Date Permit Issued	PID	Applicant's Name & Address	Telephone Number	Permit Status	Work Type	Type of Construction	Value	Estimated Start	Estimated Finish
			Property Address							
Residential Accessory Structure										
17-23	07/10/2023	77560	Polaron Energy Corp - [REDACTED]	[REDACTED]	Approved	New	Residential Accessory Structure	\$36,450.00	05/31/2023	11/30/2023
			13 Broadway Street S				Description: Ground mounted solar panel installation			

Sub Total: \$36,450.00

Total: \$36,450.00



Mailing Address:
55 Victoria Street E
PO Box 418
Kensington, PE
C0B 1M0
Tel: 902-836-3781
Fax: 902-836-3741
Email: CAO@kensington.ca
Website: www.kensington.ca

For Office Use Only	
Permit #:	17-23
Date Received:	
Date Approved:	July 10/23
PEI Planning:	
Permit Fee: \$	100 <input checked="" type="checkbox"/> Paid

DEVELOPMENT PERMIT APPLICATION

1. Property Information

Project Address: 13 Broadway St S, KENSINGTON Property Tax Number (PID): 77560
 Lot No.: 19 Subdivision Name _____ Current Zoning: R1
 Are there any existing structures on the property?: No Yes, please describe:

Land Purchased from _____ Year Purchased _____

Location of Development		Property Size	
<input type="checkbox"/> North	<input type="checkbox"/> East	Road Frontage _____	Acreage <u>0.542</u>
<input type="checkbox"/> South	<input type="checkbox"/> West	Property Depth _____	Area sq. ft. _____

2. Contact Information

APPLICANT Name: Polaron Energy Corp. Address: _____
 Phone: _____ Cell: _____
 Email: _____ Postal Code: _____

Same as Above: Name: GARY & MARIA HICKEY Address: _____
 OWNER Phone: _____ Cell: _____
 Email: _____ Postal Code: _____

CONTRACTOR, ARCHITECT OR ENGINEER Name: _____ Address: _____
 Phone: _____ Cell: _____
 Email: _____ Postal Code: _____

3. Infrastructure Components

Water Supply Municipal Private Sewage System Municipal Private

Entrance Way Permit (Department of Transportation and Infrastructure Renewal) Attached

4. Development Description

New Building Renovate Existing Addition Demolition Other Solar Panel

<input type="checkbox"/> Single Family (R1)	<input type="checkbox"/> Commercial (C1)	<input type="checkbox"/> Public Serv./Institution (PSI)	<input checked="" type="checkbox"/> Other
<input type="checkbox"/> Semi-Detached (R2)	<input type="checkbox"/> Industrial (M1)	<input type="checkbox"/> Accessory Building	
<input type="checkbox"/> Multi-Unit Res. (R3)	<input type="checkbox"/> Mini Home (RM1)	<input type="checkbox"/> Decks/Fence/Pools	

Type of Foundation	External Wall Finish	Roof Material	Chimney
<input type="checkbox"/> Poured Concrete	<input type="checkbox"/> Vinyl Siding	<input type="checkbox"/> Asphalt	<input type="checkbox"/> Brick
<input type="checkbox"/> Slab	<input type="checkbox"/> Wood Shingles	<input type="checkbox"/> Steel	<input type="checkbox"/> Prefab
<input type="checkbox"/> Pier	<input type="checkbox"/> Steel	<input type="checkbox"/> Other	<input type="checkbox"/> Other
<input type="checkbox"/> Other	<input type="checkbox"/> Other		

Number of Stories	Number of Bedrooms	Number of Bathrooms	Ground Floor (ft)
			Width _____ Length _____

Detailed Project Description: Ground mount solar panel installation

Estimated Value of Construction (not including land cost): \$36,450

Projected Start Date: May 31, 2023 Projected Date of Completion: 11/31/2023

Please provide a diagram of proposed construction:

- a) Draw boundaries of your lot.
- b) Show existing and proposed buildings.
- c) Indicate the distance between buildings.
- d) Show location of driveway.
- e) Indicate distance to property lines.

I DO SOLEMNLY DECLARE & CERTIFY:

1. That I am the Authorized Agent of the Owner/the Owner named in the Application for a permit hereto attached.
2. That the information contained herein, the attached plans, and other included documents are true and complete and the development will be constructed or carried out in accordance with the plans and specifications as submitted.
3. Providing that the Town of Kensington and/or its agents or employees are acting in good faith in the administration of the Town Bylaws, I waive all rights of actions against Town of Kensington and/or its agents or employees in respect of any damages which may be caused through the operation of any provision(s) of its Bylaw or the revoking of a permit for any cause or irregularity or nonconformity with the Bylaw or regulations adopted by the Town of Kensington.
4. I assume responsibility for damage to any Town property including: sidewalks, curbs, streets or other infrastructure and I irrevocably agree to bear the cost of remediation repair or replacement of any Town damaged by myself or by any contractors, agents or employees working on the property which is the subject of this application to the complete satisfaction of the Town of Kensington.
5. Where services are available, properties must be serviced by municipal water and sewer in accordance with the Town of Kensington Water and Pollution Control Corporations minimum standards. I am responsible for costs associated with the connection as outlined in the IRAC (Island Regulatory and Appeals Commission) Regulations. Any connection to water or sewer must be inspected by the Town of Kensington Public Works Department and 24 hrs notice must be given and inspections must be made between the hours of 8 am and 5 pm, Monday to Friday.
6. That I know of no reason why the permit should not be granted in pursuance of the Application, and I make this declaration conscientiously believing it to be true.
7. I agree to comply with all laws of Canada, Province of Prince Edward Island, and Bylaws of the Town of Kensington pertaining to the construction/and use of the development applied for herein.
8. I understand that all Development Permits are valid for 12 months and subject to a 21-day appeal period following approval as stated under the PEI Planning Act.

Further, I realize that the payment of monies for this application does not constitute approval of a permit nor approval to commence any part of the work applied for.

Signature of Applicant _____

Date: May 31, 2023

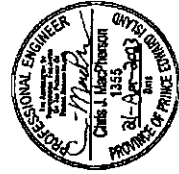
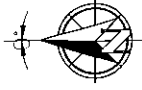

PANEL LAYOUT

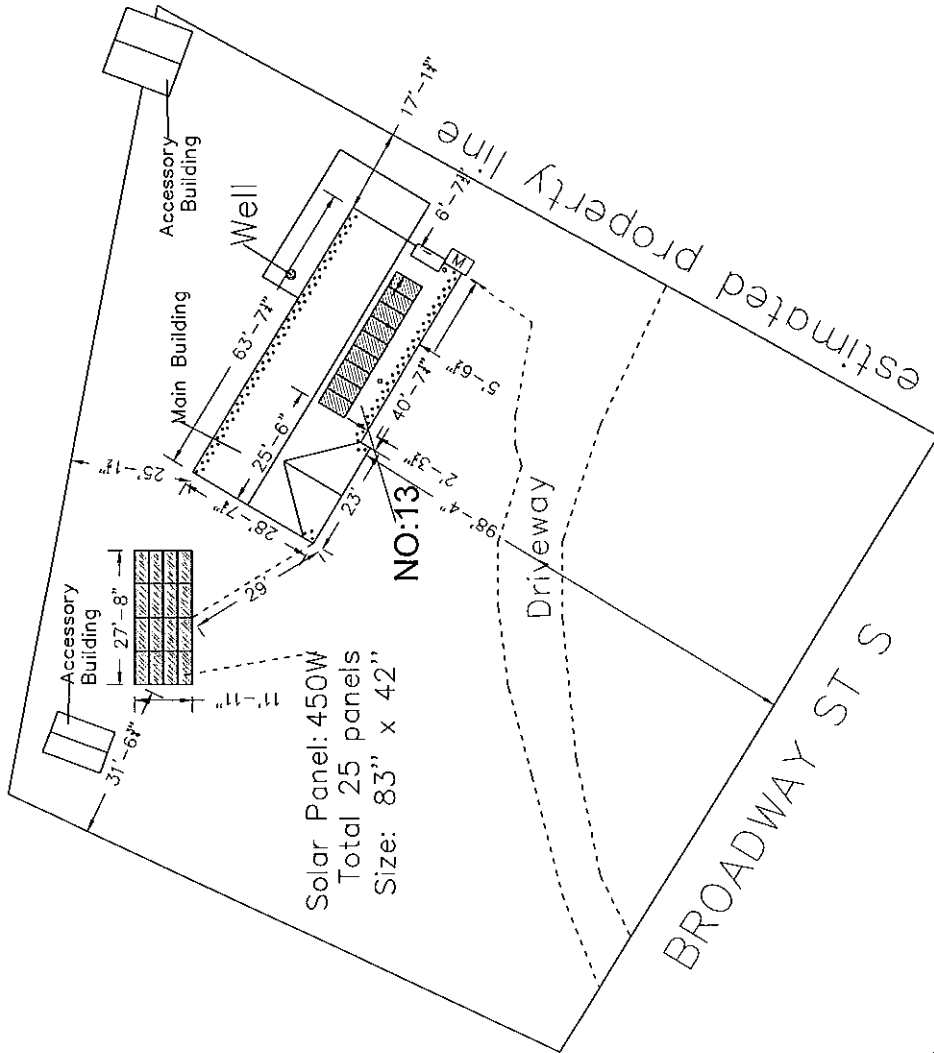

Solar Panel: 450W
 Total 25 panels
 Size: 83" x 42"

NO:13

PROJECT ADDRESS: 13 BROADWAY ST S-KENSINGTON-PRINCE EDWARD ISLAND		SOLAR PANEL LAYOUT SUBJECT TO CHANGE ACCORDING TO EXISTING CONDITIONS		DRAWING #/ REV -		ALL DIMENSIONS IN IMPERIAL UNLESS STATED OTHERWISE	
PANEL TYPE: 450		PANEL SIZE: 2000mmx1000mm		SCALE: AS SHOWN		AUTHOR: WG	
SYSTEM SIZE: 11.25kW DC		NUMBER OF PANELS: 25		DATE: 23.04.13			

SCALE: 1" = 25'

Polaron
 3781 Michels Park Ave. Unit 9 Toronto, ON M1X 3S2
 Tel: 416-977-1207 www.polaronobor.com

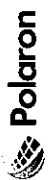

Polaron Energy Corp.
 3741 Humber Park Ave., Unit 3, Toronto, ON M3J 2Z2
 www.polaronenergy.com



REV.	DESCRIPTION	DATE
00	ISSUED FOR REVIEW	2022/04/08

PROJECT NAME:
 PROJECT ADDRESS:
 13 Broadway St S-HENNINGTON,
 Prince Edward Island
 DRAWING TITLE:
 HELIX PILE
 FOUNDATION LAYOUT
 DRAWN: J.J.
 CHECKED:
 DATE: 2022/04/13
 SCALE: N.T.S.
 DRAWING No.:
PV-301

NORMAL TABLE (16 MODULES)

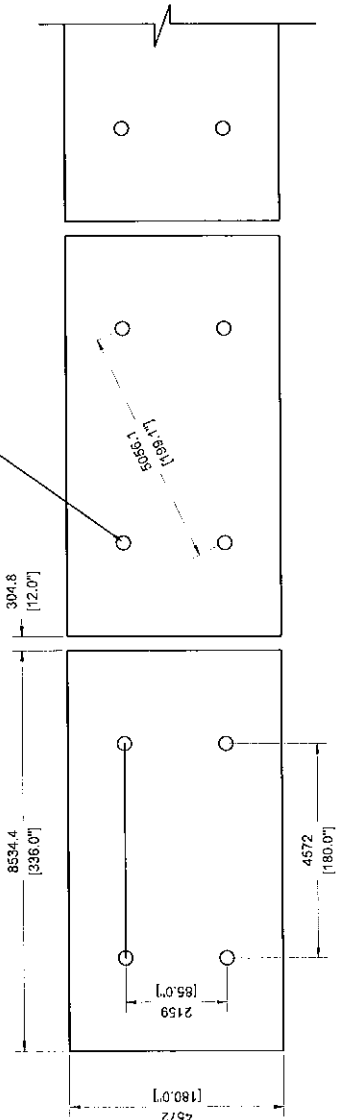

EXPANDED TABLE (24 MODULES)

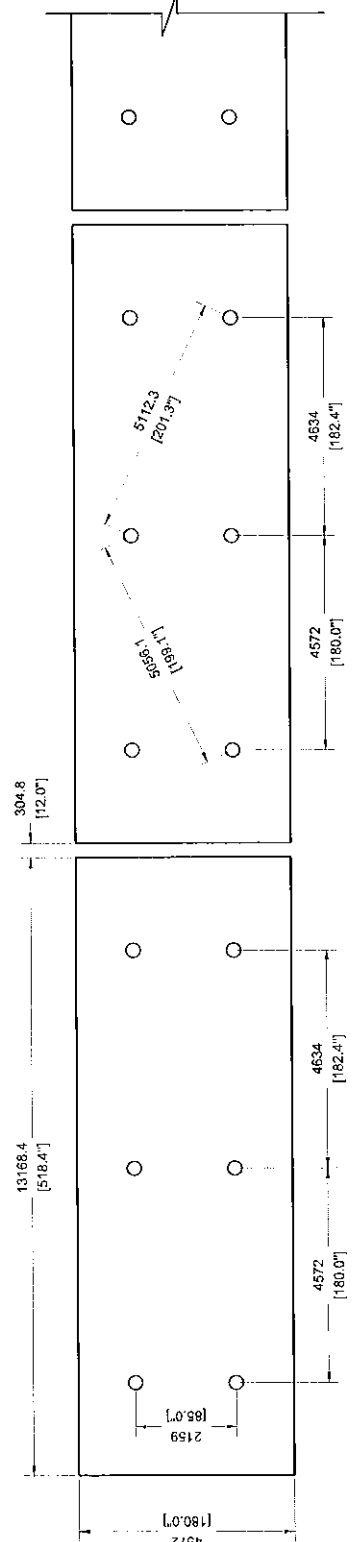

HELIX PILE FOUNDATION LAYOUT
 SCALE: N.T.S.
 unit: mm

Helical Screw Pile Requirements		
Pile Tube Outer Diameter	89 mm Min.	Steel Requirements
Pile Tubing Thickness	5.5 mm Min.	Steel Class
Helix Diameter	300 mm Min.	Steel Grade
Helix Blade Thickness	9.5 mm Min.	Finish
Helix Pitch	75 - 127 mm	Galvanization Requirements
Tube Resistance Moment	7.9 kN-m Min.	Welding Requirements
		CSA G40.21
		ASTM A500 Class B or C
		350 Mpa
		Galvanized
		ASTM A123M
		CSA W59 - M1989

Foundation Loads for Solar Panel Rack					
Hourly Wind Pressure q_{1750} (kPa)	Equivalent Velocity (km/hr)	Unfactored Vertical Resistance		Unfactored Lateral Resistance	
		lbf	kN	lbf	kN
0.30	79	1800	8.0	660	2.9
0.35	85	2150	9.6	760	3.4
0.40	91	2510	11.2	880	3.9
0.45	96	2900	12.9	970	4.3
0.50	102	3220	14.3	1080	4.8
0.55	106	3560	15.8	1190	5.3
0.60	111	3930	17.5	1320	5.9
0.65	116	4280	19.0	1420	6.3
0.70	120	4650	20.7	1550	6.9
0.75	125	5000	22.2	1650	7.3
0.80	129	5305	23.6	1740	7.7
0.85	132	5710	25.4	1840	8.2
0.90	137	6060	27.0	1950	8.7

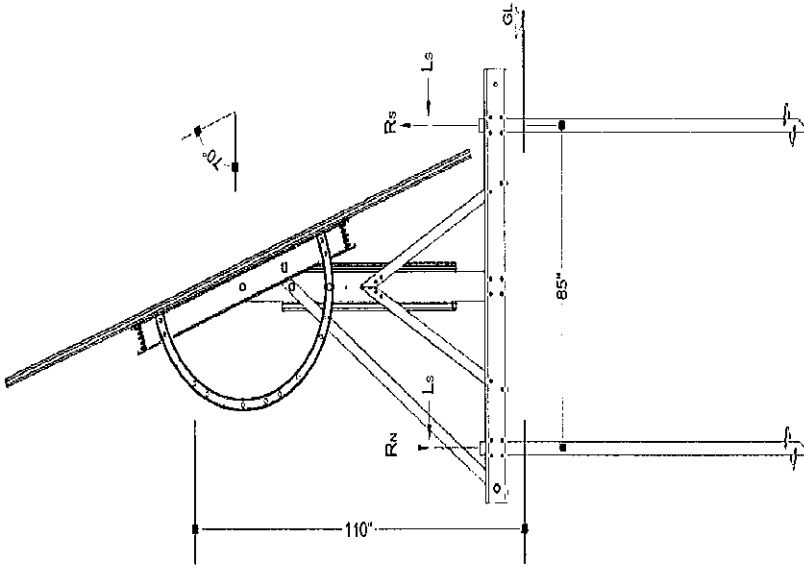
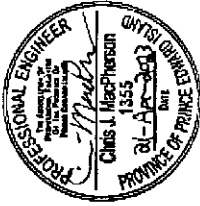

SIDE ELEVATION OF RACKING SYSTEM WITH HELICAL PILE FOUNDATION
NOT TO SCALE

Wind Data	
Location	q_{1750}
Charlottetown	0.56 kPa
Souris	0.58 kPa
Tignish	0.65 kPa

Applied Torque vs. Allowable Loads for Helical Screw Piles				
Applied Torque (lb-ft)	Cohesionless Soils (Sand, Silty Sand, Gravel)		Cohesive Soils (Silt & Clay)	
	Allowable Load (kN)		Allowable Load (kN)	
	Compressive	Tensile	Compressive	Tensile
500	16	10	9	3
750	22	15	15	8
1000	28	20	21	12
1250	34	25	27	16
1500	40	30	32	20
1750	46	35	38	25
2000	52	38	44	29
2250	58	40	50	33
2500	64	42	55	37

NOTES

1. Piles to be installed in undisturbed natural soils or compacted structural fill of known nature. Professional Engineer should be notified if significant infill areas are present in area of pile installation.
2. Ground surface to be graded in pile installation area to prevent accumulation of surface water at base of pile installation. Low areas are to be avoided or graded to allow for positive drainage unless potential issues with surface water drainage have been addressed.
3. Pile design is applicable for typical site soils encountered in Prince Edward Island. If site conditions are unknown or deemed questionable by the installer a Professional Engineer should be consulted prior to proceeding with installation. Contractor is responsible for verification of soil types and site conditions as outlined above.
4. Helix of screw pile to be installed to a minimum depth of 1650 mm to achieve adequate protection from frost. If minimum embedment depths cannot be achieved a Professional Engineer should be consulted for direction on measures to rectify embedment issues.
5. Base of solar panel racking to be installed a minimum of 150 mm and a maximum of 450 mm above ground surface. Racking is not to be in contact with the ground surface.
6. Helical screw pile foundation design is based on foundation loads for racking as provided by Pion Power.
7. Pile loadings based on Pion Power Technical Sheet for Pion POST 3-1/2" Pile with 12" diameter blade.

From: kcaseley@kensington.ca
Sent: Tuesday, July 4, 2023 1:36 PM
To: cao@kensington.ca
Subject: Fw: [TOWN OF KENSINGTON] Permit application for solar - 13 Broadway St S, KENSINGTON

We have ourselves a potential Council item haha

From: Hope Parnham <hparnham@outlook.com>
Sent: Tuesday, July 4, 2023 1:07 PM
To: kcaseley@kensington.ca <kcaseley@kensington.ca>
Subject: RE: [TOWN OF KENSINGTON] Permit application for solar - 13 Broadway St S, KENSINGTON

Hi Kim

Section 4.24 addresses both Accessory Structures and Buildings (see below). I've highlighted the relevant regulations for a structure. The other points in this section relate to buildings only. They appear to meet the setback requirements but the distance to the rear lot line isn't labeled – this should be confirmed. They also are under the maximum height permitted.

The Bylaw is silent on solar arrays specifically, but one could argue that it is a similar structure to a satellite dish or wind turbine, in which case council can issue a special permit for the structure. To avoid any potential conflict in interpretation I would suggest going that route. The new bylaw – as currently drafted – is clear on solar arrays and would not require council's approval for this application.

If you do take it to Council, **my recommendation is to approve the application.**

Best regards,
Hope

4.24. Accessory Structures

1) Accessory uses, buildings and structures shall be permitted on any lot but shall not:

- a) be used for human habitation except where a dwelling is a permitted accessory use;
 - b) be located within the front yard or flanking side yard of a lot;
 - c) be built closer than three (3.0') feet (0.9 m.) to any lot line;
 - d) except in an industrial zone, commercial zone or on a farm property exceed fifteen (15.0') feet (4 m.) in height above grade, unless a special permit has been issued by Council allowing a greater height in order to achieve architectural harmony with the main building or within the neighbourhood;
 - e) except in an industrial zone, commercial zone or on a farm property exceed 50% of the total floor area of the main building on the lot;
 - f) be built within seven (7) ft. of the main building on the lot;
 - g) exceed a maximum of two (2) buildings per property.
- 2) All accessory buildings shall be included in the calculation of maximum lot coverage as described in the Lot Requirements for the applicable zone. **Satellite dishes, wind turbines or similar structures greater than 3 feet in diameter shall not be erected in any zone in the Town unless a special permit has been issued by Council.**
- 3) Notwithstanding the above provisions, Council may issue a special development permit

for an accessory structure located within the front yard or flanking side yard of a lot, where Council is satisfied the structure will be architecturally compatible with adjacent structures and no permanent injury would be caused to adjoining properties, subject to such conditions as Council may impose.

From: kcaseley@kensington.ca <kcaseley@kensington.ca>
Sent: Tuesday, July 4, 2023 9:36 AM
To: Hope Parnham <hparnham@outlook.com>
Cc: cao@kensington.ca
Subject: Fw: [TOWN OF KENSINGTON] Permit application for solar - 13 Broadway St S, KENSINGTON

Good morning Hope,

We received a development permit application for a ground-mounted solar system. Can you review the attached application and let us know of anything that we should address - it is the first ground system that we have dealt with. The property appears to have two accessory structures already.

Many thanks,

Kim

From: cao@kensington.ca <cao@kensington.ca>
Sent: Wednesday, May 31, 2023 11:52 AM
To: kcaseley@kensington.ca <kcaseley@kensington.ca>
Subject: Fw: [TOWN OF KENSINGTON] Permit application for solar - 13 Broadway St S, KENSINGTON

Geoff Baker, CAO
Town of Kensington
Tel: (902) 836-3781
Cell: (902) 439-8849

From: Project Admin <projectadmin@polaronsolar.com>
Sent: Wednesday, May 31, 2023 11:48 AM
To: cao@kensington.ca <cao@kensington.ca>
Cc: Yexiang Zhu <yzhu@polaronsolar.com>; Lucy Chen <lchen@polaronsolar.com>; Jason Hibbard <jason@sunly.ca>; Danielle Dwinnell <danielle@sunly.ca>; Operations Sunly <operations@sunly.ca>
Subject: [TOWN OF KENSINGTON] Permit application for solar - 13 Broadway St S, KENSINGTON

Dear Officer,

Please find the attached permit application for the above address. Feel free to contact us if you have any questions.

Regards,



Toll-Free: [1-888-318-1988](tel:1-888-318-1988) | Office: [647-557-1207](tel:647-557-1207)

TOWN OF KENSINGTON – MEMORANDUM

TO: MAYOR AND TOWN COUNCIL, CAO

FROM: ROBERT WOOD, CUC MANAGER

DATE: JUNE 2023

SUBJECT: JUNE 2023 - CREDIT UNION CENTRE REPORT

ATTACHMENT: STATISTICAL REPORT

JUNE 2023

Fitplex

- Hours of operation are 5:00 am – 10:00 pm daily.
- Staffed Hours are Monday to Friday 4:00 pm-8:00 pm

Arena

- The arena boards and matting were finished in June, 2023.
- The first two rows of the stands are removed to allow for the new boards to be placed and a walkway created, new stairways will be built by KMP to accommodate exits and will be done by July 30.
- Railings will be installed by Eddie Arsenault before Harvest Festival
- Public washrooms are under renovations with flooring and painting finished, waiting on fixtures and custom ordered stalls.
- Painting continues with interior of the arena being painted to white with black trim to brighten the arena.
- LED lightning has been ordered by Mid Isle Electric and will be installed upon availability.
- Spray Net will begin painting beams and building in July.
- Paving is scheduled for July.

- Electrical upgrades to system will be needed to provide power to new Ice Plant and a report by WSP will be sent to Town.

Kensington Cash Draw

• June 7	183.00
• June 14	188.00
• June21	178.00
• June 28	182.00
Total	731.00

Ball Fields

- Ballfield bathroom was upgraded for the season.
- Ballfield netting is up, and new addition added to bottom of netting to go to the ground.
- Ballfield lights repaired and working.
- Danny Hughes Memorial Tournament is Booked for July 21-23
- The Mens Eastern Canadians tournament has been booked for Kensington this fall by Softball PEI Sept 8-10

Senior Center

- NTR

Tennis \ Pickleball Courts KISH

- Nets are up for the season and windscreens installed.
- One Pickle Ball is setup and two tennis nets.

CUC Property

- Skate Park and ball hockey has seen steady use.
- The deck by the pond has been upgraded with new railing and deck.

- Kensington North Watershed and Town has received funding to construct a new trail through the wooded area behind the ballfields, including signage, benches and flower beds.

Upcoming Events

- Canada Day Ceremony July 1,2023
- Danny Hughes Memorial Ball tournament July 21-23,2023
- Kensington Harvest Festival Aug 19-23,2023
- Eastern Canadians softball Sept 8-10,2023



to Town Council is an opportunity for the Mayor to provide feedback to Council, Staff, Residents, and other interested Stakeholders about activities of the Mayor on their behalf since the last Council meeting. It will include, as much as possible, a summary of information from meetings and discussions on behalf of the Town of Kensington. Any decisions to be made on behalf of the Town will be brought forward to Council for decisions.

The Mayor is the designated spokesperson for the town and communicates decisions made by Town Council. The Mayor chairs the monthly Town Council Meetings and the monthly Committee of Council meetings. All efforts are made to keep discussions and decisions transparent as we represent the town on behalf of the residents. Agenda's (along with supporting information) for Committee of Council meetings and Town Council meetings are posted on the town website on the Friday afternoon prior to the meeting. (www.kensington.ca)

Committee of Council meetings are held on the 4th Monday of each month (except July and August and December) at 6:30 pm and Town Council meetings are held on the 2nd Monday of each month at 7:00 pm. The agenda's (along with supporting information) are emailed to the County Line Courier, Journal Pioneer, CTV, and CBC on the Friday afternoon prior to the meetings.

– The Town of Kensington welcomed “Queer Ride 2023” on Sunday July 23. The ride started in Charlottetown and came to Kensington along the Central Coastal Drive. There were approximately a dozen motorcycle riders, with their bikes decorated to suit the occasion. All participants gathered at the Kensington Town Clock area for the purpose of taking pictures and to accept donations to PEERS alliance.

– I had the pleasure of attending the 25th anniversary of Malpeque Fine Iron in New Annan when I presented Eric and Dianne Schurman with a Certificate in recognition of this milestone on behalf of Town Council. It is amazing the artistic work they do by taking scrap products and turning them into Art. If you have not had the pleasure of visiting them and seeing what they can do, it is worth the trip.

– I attended a celebration for Denny and Gayle Hopping on the occasion of their 60th wedding anniversary. I presented them with a Certificate of Congratulations on behalf of Town Council.

As the town of Kensington has continued to grow and we continue to attract more people to the area through our association with the Heart of PEI and the Kensington Summer Music Series, the issue of insufficient downtown vehicle parking is becoming of greater concern. Businesses in the downtown core area are continuing to attract more business and the Train Station parking lot is becoming more congested. It may be time for Town Staff to evaluate the potential and cost to convert the Town owned property located off School Street (behind the Provincial Credit Union) into a parking lot. When we had a public meeting on this many years ago, we received feedback from the community that this should be used for either vehicle parking or parkland or a combination thereof. While parkland is important, we do have some parkland close by on Pleasant Street which we have not developed as yet, other than as green space. As a Town, we need to evaluate what we can do to accommodate our growth and provide sufficient and acceptable vehicle parking to meet and accommodate the downtown core businesses. We have also lost at least two spaces with the installation of the Confederation Trail Crosswalk Lights on Broadway Street North. I am requesting Town Council to direct Mr.



Baker, CAO to evaluate and assess this property off School Street for conversion to a parking lot, with cost estimates and to source potential funding sources to assist in the expense? Furthermore, I would request we direct Mr. Baker, CAO to have our engineers assess the current train station parking lot parking layout to determine if more parking spaces could be made available with a different layout and still be able to provide sufficient access to service the businesses in the area. Even if we can find an additional few spaces, they will be invaluable.

Rowan Caseley, Mayor

Town of Kensington

Town of Kensington - Request for Decision

Date: July 25, 2023	Request for Decision No: 2023-37 (Office Use Only)																
Topic: Credit Union Centre – Rural Growth Initiative (RGI) Funding Program																	
Proposal Summary/Background: <p>Town staff have made an application to the Province of PEI’s Rural Growth Initiative (RGI) Funding Program to undertake several projects/improvements at the Credit Union Centre and Fire Hall (Fire Departments can receive a maximum of \$50,000 in funding according to fund guidelines). The application requires an authorizing resolution to be considered for funding. The scope of the funding application includes the following projects and cost estimates:</p> <table style="width: 100%; border-collapse: collapse;"><tr><td style="width: 80%;">1. Heat Pumps</td><td style="text-align: right;">\$9,990.00</td></tr><tr><td>2. Auto Extrication Equipment (Jaws of Life)</td><td style="text-align: right;">\$49,985.00</td></tr><tr><td>3. Credit Union Centre (Floor Scrubber)</td><td style="text-align: right;">\$6,943.00</td></tr><tr><td>4. Ice Edger</td><td style="text-align: right;">\$6,125.00</td></tr><tr><td>5. Public Washrooms (Plumbing and Fixtures)</td><td style="text-align: right;">\$40,700.00</td></tr><tr><td>6. Public Washrooms (Floor and Countertop)</td><td style="text-align: right;">\$5,025.00</td></tr><tr><td>7. Public Washrooms (Change Tables, Accessories)</td><td style="text-align: right;"><u>\$5,021.00</u></td></tr><tr><td> Total</td><td style="text-align: right;"> <u>\$123,789.00</u></td></tr></table> <p>The RGI may cover up to 75% of qualifying expenditures associated with the projects. The Fire Chief has indicated that they may want to substitute the ‘replacement of breathing apparatuses’ for the Auto Extrication Equipment however this can be modified in consultation with the funder following approval of the Town’s application.</p> <p>It is recommended that Town Council approve a resolution to formally authorize the submittal of the funding application to the RGI Community Revitalization Program.</p>		1. Heat Pumps	\$9,990.00	2. Auto Extrication Equipment (Jaws of Life)	\$49,985.00	3. Credit Union Centre (Floor Scrubber)	\$6,943.00	4. Ice Edger	\$6,125.00	5. Public Washrooms (Plumbing and Fixtures)	\$40,700.00	6. Public Washrooms (Floor and Countertop)	\$5,025.00	7. Public Washrooms (Change Tables, Accessories)	<u>\$5,021.00</u>	 Total	 <u>\$123,789.00</u>
1. Heat Pumps	\$9,990.00																
2. Auto Extrication Equipment (Jaws of Life)	\$49,985.00																
3. Credit Union Centre (Floor Scrubber)	\$6,943.00																
4. Ice Edger	\$6,125.00																
5. Public Washrooms (Plumbing and Fixtures)	\$40,700.00																
6. Public Washrooms (Floor and Countertop)	\$5,025.00																
7. Public Washrooms (Change Tables, Accessories)	<u>\$5,021.00</u>																
 Total	 <u>\$123,789.00</u>																
Benefits: <ul style="list-style-type: none">• Will result in significant improvements to the Credit Union Centre and Fire Department operations.• Will provide upgraded washrooms for users of the Credit Union Centre.																	

- Will provide a safer, more effective operation of the Fire Department.

Disadvantages:

- None noted.

Discussion:

Town Council’s Capital Plan for the Credit Union Centre for 2023/24 totalled \$2,310,835.00 and included facility upgrades (\$2,187,785.00, funded through ICIP), washroom replacements (\$100,000.00), ice edger (\$6,250.00), fitplex equipment replacement (\$10,000.00), skateboard park improvements (5,000.00), and a utility trailer (\$1,800.00). The Capital Plan contemplated cost sharing the capital expenses through the RGI funding program, long term borrowing, ICIP and the MBCU 50/50 account. Not all of the desired 2023/24 capital items for the CUC are included in the current RGI application (or other funding applications) due to the limitations of the programs. Staff will continue to seek out appropriate funding sources to allow the remaining capital items to be purchased in 2023/24.

Town Council’s Capital Plan for the Fire Department totalled \$165,000.00 and included the purchase of a mechanical floor cleaner (\$5,000.00), SCBA Replacement (\$78,000.00), Jaws of Life (\$50,000.00), Heat Pumps (\$11,000.00), Facility Upgrades (\$13,000.00), Pumper Truck Primer (\$4,000.00), and Cribbing (\$4,000.00). The Capital Plan contemplated cost sharing the capital expenditures through the RGI funding program and long-term borrowing. As indicated previously, the maximum amount of funding accessible through the RGI program for the fire department is \$50,000. It is proposed that Town Council authorize staff to proceed with the application as indicated in this RFD, and staff will continue to seek out appropriate funding sources to allow the remaining capital items to be purchased in 2023/24.

It is recommended by the CAO that Town Council proceed with authorizing staff to submit the funding application as presented.

Options:

1. Authorize the submittal of the funding application, as proposed.
2. Not authorize the submittal of the funding application.

Costs/Required Resources:

Estimated at \$123,789.00 plus

Source of Funding:

MBCU 50/50

HST		Fire Department Current Revenue
Town	\$30,947.25	RGI Funding Program
RGI	<u>\$92,941.75</u>	
	\$123,789.00	

Recommendation:

It is recommended that Town Council consider and adopt the following resolution:

Resolution 1

BE IT RESOLVED THAT Kensington Town Council authorize staff to proceed with submitting a Rural Growth Initiative Funding Program application to the Province of PEI to facilitate the Kensington Credit Union Centre and Kensington Fire Department 2023 Capital Projects, as presented and in the amount of \$123,789.00. Town Council understands that they will be responsible for any future operations and maintenance costs associated with and resulting from the project.

**Town of Kensington
2023/24 Proposed Capital Plan**

Project Category	Budget 2023/24	Municipal Funding	MBCU 50/50/Other	Federal/Gas Tax	Provincial/Federal Funding (RGI, MSC, ICIP, etc)	Long Term Borrowing
Credit Union Centre						
Facility Upgrades	\$2,187,785				\$1,604,329	\$583,456
Washroom Replacement	\$100,000		\$25,000		\$75,000	
Ice Edger	\$6,250	\$6,250				
Fitplex Equipment Replacement	\$10,000		\$10,000			
Skateboard Park Improvements	\$5,000		\$5,000			
Utility Trailer	\$1,800		\$1,800			
Total Credit Union Centre	\$2,310,835	\$6,250	\$41,800	\$0	\$1,679,329	\$583,456
Police Department						
Police Equipment Replacement	\$4,000	\$4,000				
Office Equipment Replacement	\$1,500	\$1,500				
Total Police Department	\$5,500	\$5,500	\$0	\$0	\$0	\$0
Fire Department						
Mechanical Floor Cleaner	\$5,000				\$2,500	\$2,500
SCBA Replacement	\$78,000				\$39,000	\$39,000
Jaws of Life	\$50,000				\$25,000	\$25,000
Heat Pump (Fire Hall)	\$11,000				\$11,000	
Facility Upgrades	\$13,000				\$6,500	\$6,500
Pumper Truck Primer	\$4,000				\$2,000	\$2,000
Cribbing	\$4,000				\$2,000	\$2,000
Total Fire Department	\$165,000	\$0	\$0	\$0	\$88,000	\$77,000
Town Hall/General Government						
Website Development	\$12,500	\$12,500				
Business Park Signage	\$20,000	\$6,660			\$13,340	
Official Plan/Development Control Bylaw Review	\$5,000	\$2,500			\$2,500	
Town Hall Sign Replacement	\$10,000	\$10,000				
Total Town Hall/General Government	\$47,500	\$31,660	\$0	\$0	\$15,840	\$0
Public Works						
Bobcat Replacement	\$135,000	\$135,000				
Broadway Street S Sidewalk Replacement	\$106,900			\$106,900		
5-way Blade for Trackless	\$8,400	\$8,400				
Broadway Street South Sidewalk Extension	\$247,020				\$222,318	\$24,702
Utility Pole Relocation (Sidewalks)	\$244,245			\$244,245		
Maintenance Shop Upgrades (Concrete Floor Repair, Doors)	\$15,000	\$15,000				
Dump Trailer	\$14,000	\$14,000				
Total Public Works	\$770,564	\$172,400	\$0	\$351,145	\$222,318	\$24,702
Parks/Recreation/Railyards						
Park and Recreation Improvements	\$34,323			\$34,323		
Freight Shed Upgrades	\$50,000	\$50,000				
Core Area Redevelopment (Plan Development)	\$100,000	\$10,000			\$90,000	
Total Parks/Recreation/Railyards	\$184,323	\$60,000	\$0	\$34,323	\$90,000	\$0
Water and Sewer Utility						
Broadway Street South W/S Extension	\$1,414,401				\$1,414,401	
Water and Sewer System Capacity and Water Tower Pre-Design	\$80,000			\$80,000		
Wellfield Signage	\$2,500	\$2,500				
Boradway Street North W/S Extension	\$1,000,000				\$733,300	\$266,700
Total Water and Wastewater	\$2,496,901	\$2,500	\$0	\$80,000	\$2,147,701	\$266,700
Total	\$5,980,623	\$278,310	\$41,800	\$465,468	\$4,243,188	\$951,857



Rural Growth Initiative Application Form 2023-24

Date Received:	<input type="checkbox"/> Community Revitalization Program	<input type="checkbox"/> Economic Growth Program
File Number:	<input type="checkbox"/> Community Capacity Program	<input type="checkbox"/> Inclusive Communities Program

Privacy Statement: Personal information on this form is collected under section 31I of the *Freedom of Information and Protection of Privacy Act* R.S.P.E.I. 1988, Cap. F-15.01, as it relates directly to and is necessary for the programs administered under the Rural Growth Initiative. If you have any questions about this collection of personal information you may contact the Director of Rural and Regional Development - PO Box 1180, Montague, PE C0A 1R0 or call 902-838-0662.

INSTRUCTIONS

- Please read the program guidelines prior to completing the application.
- Please fill out the **entire** application form and ensure you attach the proper documents. See the checklist at the end of this application to ensure you submit the necessary documents. Applications will not be assessed until all required information is submitted.
- Projects requesting more than \$250,000 from the Rural Growth Initiative are required to fill out Appendix A.
- If you have any questions, please contact the Community Development Officer in your region (contact information on p. 5).

APPLICANT INFORMATION

Organization Name (*Legal operating name*): **Town of Kensington**

Mailing Address: **PO Box 418
Kensington, PE C0B 1M0**

Phone Number: 902-836-3781	E-mail: cao@kensington.ca
-----------------------------------	----------------------------------

HST Number: 108127416	HST/GST Rebate % 100
------------------------------	-----------------------------

Primary Contact Information
(this should be the person who will oversee the project and be able to answer any questions concerning project activities):

Name: Geoff Baker	Title/Position: CAO
--------------------------	----------------------------

E-mail: cao@kensington.ca	Phone: 902-836-3781
----------------------------------	----------------------------

Secondary Contact Name:
(this should be the person able to answer questions about the project if the primary contact is unavailable)

Name: Robert Wood	Title/Position: Manager CUC
--------------------------	------------------------------------

E-mail: cuc@kensington.ca	Phone: 902-836-3509
----------------------------------	----------------------------

Organization Overview

What year was your organization established? **1914**

How many volunteers/members are involved with the organization?

Please list activities, events, and services that your organization provides (you may attach a newsletter or calendar of events).
Municipality that services Kensington and Area in an all areas and including Kensington Credit Union Centre Arena, Fire dept , Pool and all municipal services.



Rural Growth Initiative Application Form 2023-24

PROJECT INFORMATION

Project Title: Kensington Credit Union Centre Arena and Kensington Fire Department

Project Location Address: 25 Garden drive and 16 Mccarville drive

Expected Start Date: July 15, 2023 Expected Completion Date: Oct 31, 2023

Requested Funding: 87,784.50

Project Overview: Please answer the following questions. You may attach separate documentation if space insufficient.

Provide a brief description of the project, including the end-result or ultimate outcome of the project:
This project includes upgrades to Kensington Credit Union Centre and the Kensington Fire Hall. The arena is renovating the public washrooms, upgrading to a automatic floor scrubber and replacing the ice edger.

The Fire department is purchasing a Jaws for Life and installing heat pumps.

What benefits will the completed project bring to the surrounding community, region and/or province?
The Credit Union Centre is a 50 year building and repairs and maintenance are a priority. It is a home to local minor sport groups and is a local meeting area. The benefits include increasing active living for all ages, updating the facility to provide programming for the area and making an energy efficient building.
The fire dept provides emergency services to the Town of Kensington and surrounding areas. The benefits include an energy efficient building and a battery operated Jaws for Life will eliminate the need to carry gas and will prevent hoses from getting tangled.

For Community Revitalization Projects (renovation projects) ONLY:
Please describe how the end-product of the project will be maintained AFTER the project. This includes who will be responsible for maintaining the end products and how they will be financed long-term. You may attach additional documentation to support your response such as an operational plan. Please reference these documents in your response below.

For projects purchasing or constructing equipment that will result in electric or heating energy efficiency ONLY

Was an energy audit completed? Yes No

Date of last energy audit completed: _____

Please attach energy audit to application.

Note: If you will be applying for an efficiency PEI rebate as part of your project, you may be required to complete an energy audit. Please be in touch with efficiency PEI.



Rural Growth Initiative Application Form 2023-24

Project Timeline: Please name when major project milestones or outcomes are planned to be completed. You may attach a separate project timeline if space is insufficient.

<i>Project Milestone/Outcome:</i>	<i>Date of completion:</i>
Arena public washrooms	Aug,2023
Ice Edger \Floor scrubber	Sept 2023
Jaws for Life	Oct 2023
Heat pump Install	Oct 2023

FOR PROJECTS REQUESTING FUNDING GREATER THAN \$250,000, APPLICANTS ARE REQUIRED TO FILL OUT APPENDIX A FOUND AT THE END OF THIS APPLICATION.

AUTHORIZED SIGNING OFFICERS

Please provide signatures below for individuals authorized to sign agreements, amendments and financial claim forms.

Name	Title/Position	Signature
1. Geoff Baker	CAO	
2. Rowan Caseley	Mayor	
3.		
4.		

PROPOSED PROJECT EXPENDITURES

If space not sufficient, please attach separate budget to application

Item	Vendor and/or Quote Number	Estimated Amount
Heat Pumps	Atkantic Heating and Cooling	\$ 9,990.00
Jaws of Life	MES	\$ 49,985.00
Floor scrubber	Uline	\$ 6,943.00
Ice edger	Saunders equipt	\$ 6,125.00
Public Washrooms	Moase Plumbing	\$ 40,700.00
Public washrooms -Floor Counter	Tops to floors	\$ 5,025.00
Public washrooms change tales and accessories	Uline	\$ 5,021.00
TOTAL		\$ 123,789.00

ALL QUOTES MUST BE ATTACHED TO THE APPLICATION



Rural Growth Initiative Application Form 2023-24

PROJECT CONTRIBUTORS			
Please name <u>ALL</u> potential sources of funding for your project (including funds requested from the Rural Growth Initiative). Please attach verification of funding to application. If space insufficient, a separate list can be attached to the application.			
Source	Amount	Is amount confirmed (select one)?	
		Confirmed	Pending
Rural Growth Initiative	\$ 92,841.75	<input type="checkbox"/>	<input checked="" type="checkbox"/>
Applicant Contribution	\$ 30,947.25	<input checked="" type="checkbox"/>	<input type="checkbox"/>
		<input type="checkbox"/>	<input type="checkbox"/>
		<input type="checkbox"/>	<input type="checkbox"/>
		<input type="checkbox"/>	<input type="checkbox"/>
		<input type="checkbox"/>	<input type="checkbox"/>
		<input type="checkbox"/>	<input type="checkbox"/>
		<input type="checkbox"/>	<input type="checkbox"/>
		<input type="checkbox"/>	<input type="checkbox"/>
		<input type="checkbox"/>	<input type="checkbox"/>
TOTAL (must equal total proposed project expenditures from p. 3)	\$ 123,789.00		

APPLICANT CHECKLIST
<p>Applications will be reviewed for completion and assessed based on the program guidelines. Applications will not be assessed until all necessary documentation is received. Please review the checklist below to ensure your application is not delayed due to missing information. Please note that additional information may be required for some projects.</p>
<ul style="list-style-type: none"> <input checked="" type="checkbox"/> Project Quotes (i.e. quotes from contractors) <ul style="list-style-type: none"> • Projects with heat pumps must be installed by a contractor on efficiency PEI's Network of Excellence list. Heat Pumps must also be NEEP certified and listed under the NEEP database found at: https://ashp.neep.org/#/ <input type="checkbox"/> Proof of applicant's portion of project costs (i.e. bank statements) <input type="checkbox"/> Proof of funding agreements with other project contributor(s) (i.e. ACOA agreement) <input checked="" type="checkbox"/> Proof of Commercial General Liability Insurance (\$2M min; PEI Government additional insured) <input type="checkbox"/> Board of Directors/Council resolution supporting project (i.e. meeting minutes) <input type="checkbox"/> Copy of Energy Audit if applicable <input type="checkbox"/> Declaration of Tax Status Form – If the grant request is over \$10,000, please note Section 4 a) and b) on the Form. <input checked="" type="checkbox"/> Proof of PEI Incorporated Status (CRA Business or Charitable Tax Number). <input type="checkbox"/> Appendix A (For projects requesting \$250,000 in funding or more only) <input type="checkbox"/> Relevant Building Permits (if applicable) <input type="checkbox"/> Description of Environmental Assessments taken (if applicable) <input type="checkbox"/> Strategic, business, operational, or building plans relevant to project



Rural Growth Initiative Application Form 2023-24

DECLARATION			
I hereby declare that all information contained in and/or attached to this application is true, complete and accurate.			
Applicant Name (Print)	Title/Position	Signature	Date
CONTACT INFORMATION			
If you have any questions about your application or for more information about the Rural Growth Initiative or other programs delivered by Rural and Regional Development please contact the Community Development Officer in your region.			
Area	Name	Phone	E-mail
West Prince	Ellen Rennie	902-853-0104	emrennie@gov.pe.ca
East Prince/Central Queens	Kellie Mulligan	902-887-3975	kamulligan@gov.pe.ca
Evangeline (Bilingual)	Giselle Bernard	902-854-3680	gbbarnard@gov.pe.ca
Southern Kings/Queens	Sonia Dixon	902-838-0618	sddixon@gov.pe.ca
Eastern Kings	Chris Blaisdell	902-208-0032	cwblaisdell@gov.pe.ca
PLEASE SUBMIT COMPLETED APPLICATIONS TO THE COMMUNITY DEVELOPMENT OFFICER IN YOUR REGION			



APPENDIX A

To be filled out for projects requesting funding greater than \$250,000

ECONOMIC BENEFITS:

Please describe how the end result of your project will contribute to economic development or have economic benefits for PEI.

You may attach documentation such as a business or strategic plan to support your response. Please reference these documents in the below space.

REGIONAL BENEFITS

Please describe the regional benefits your project will result in. This could include how the project will result in partnerships with other groups or have positive impacts on communities beyond the one where your organization is located.

You may attach separate documentation to support your response. Please reference these documents in the below space.



Rural Growth Initiative Application Form 2023-24

PROJECT MANAGEMENT

Please answer the following questions. If you have a separate project management plan, you may attach it to the application to supplement your responses.

Who will be the main project manager? What are their responsibilities?

Please use the space below to identify the main project risks and how will these be mitigated throughout the project.

Project Risk	Mitigation Strategy

PLEASE ATTACH PROJECT DESIGN PLANS IF APPLICABLE



Rural Growth Initiative Application Form 2023-24

COMMUNITY CONSULTATION:

Please describe the type of community consultations conducted that resulted in support for your project. This could include holding a community meeting, conducting a strategic planning process with community members, or some other assessment process.

You may attach separate documentation to support your response. Please reference these documents in the below space.

Town of Kensington - Request for Decision

Date: August 1, 2023	Request for Decision No: 2023-38 (Office Use Only)
Topic: Guaranteed Basic Income Benefits for Prince Edward Island	
Proposal Summary/Background: <p>Marie Burge and Wayne Easter of the PEI Working Group for a Livable Income (WGLI) made a presentation to Town Council at their July meeting, on a proposal for a Guaranteed Livable Basic Income Benefit for Prince Edward Island. Their presentation was followed by a <i>request for Town Council to consider adopting a resolution to direct Mayor Caseley to write a letter to the Prime Minister, PEI Members of Parliament, and the Premier of Prince Edward Island, calling on these orders of government to work towards developing a Guaranteed Livable Basic Income to alleviate poverty and homelessness, and to ensure that everyone has sufficient income to meet their basic needs.</i></p>	
Benefits: <ul style="list-style-type: none">• Will help encourage the Provincial and Federal Governments to come together and work towards developing a Guaranteed Livable Basic Income pilot project for the Province of PEI.• Will encourage the development of a Guaranteed Livable Basic Income that can be scaled up to be used across Canada.	
Disadvantages: <ul style="list-style-type: none">• None noted.	
Discussion: <p>The PEI WGLI is a coalition of 10 – 12 community groups and individuals and was established in 2003. The WGLI defines livable income as sufficient resources to cover each person’s basic human needs: healthy and culturally appropriate food; safe and affordable housing; safe and affordable transportation; required medications; dental care; access to child and elder care; continuing education and training; and the support and freedom to participate in their community and to cover inevitable emergencies.</p> <p>The WGLI further states that Basic Income is an essential part of the social safety net, without which</p>	

the success of the other many elements of the social safety net is severely hampered. So it is not improved healthcare OR basic income. It must be improved programs all around AND basic income.

From a practical perspective, the WGLI defines a basic income guarantee as a cash payment sent regularly to individuals who need it to meet their basic needs and live in dignity. It would be available to any adult who has less income than they need to meet their basic needs.

An information package provided by the PEI Working Group for a Livable Income is being circulated with this request for decision.

Options:

1. Authorize the Mayor to send a letter to the Prime Minister, PEI MP's and the Premier, as proposed.
2. Not authorize the Mayor to send a letter.

Costs/Required Resources:

N/A

Source of Funding:

N/A

Recommendation:

It is recommended that Town Council consider and adopt the following resolution:

Resolution

WHEREAS the Town of Kensington recognizes the importance of addressing income inequality;

AND WHEREAS the Town of Kensington recognizes that the downstream impacts of poverty within our community puts unsustainable pressure on our limited resources to deliver necessary public services as we struggle to keep up with downloaded responsibilities;

AND WHEREAS a Guaranteed Livable Basic Income Program has the potential to provide financial stability to our residents, improve our residents physical and mental health, reduce poverty, and stimulate local economic growth;

AND WHEREAS a joint effort between the Provincial and Federal Government is essential to design, implement, and fund a Guaranteed Livable Basic Income program effectively;

BE IT RESOLVED that the Town Council of the Town of Kensington hereby direct the Mayor to draft and send a letter to the Prime Minister of Canada, PEI Members of Parliament, and the Premier of Prince Edward Island urging them to work collaboratively to develop a Guaranteed Livable Basic Income to eradicate poverty and homelessness, and to ensure that everyone has sufficient income to meet their basic needs.

Prince Edward Island Principles for a Basic Income Guarantee

The first principle of Basic Income Guarantee is that Indigenous autonomy and self-determination must be predominant. It is the right of Indigenous people to determine whether a basic income is delivered in their communities and, if so, what form it will take and how it will be implemented.

Additionally, a successful Basic Income Guarantee for Prince Edward Island will

1. Be universal and unconditional to all adult residents, subject to income, but regardless of work status or relationship status.
2. Recognize that not all people have the same basic needs and some will need more support in addition to a Basic Income Guarantee.
3. Transform some social programs and services, such as income support, while maintaining others, such as disability support.
4. Be administered through the income tax system, and respond to people's changing income levels in a timely manner.
5. Be sufficient to provide for people's basic needs. To us, this means enough to pay rent or mortgage and monthly utility bills, to buy nutritious food and medicine, to use transportation, to continue learning, to access childcare or eldercare, to participate in the community, and to cover emergencies.
6. Be grounded in human rights, as opposed to charity, and be provided with dignity and respect for recipients.
7. Recognize that human health and wellbeing depend on the health and sustainability of the natural environment.
8. Be designed and planned based on inclusive and meaningful public consultation, with a continuing role for community throughout implementation.
9. Make investment in people the priority for all government spending and economic development.
10. Be evidence-based, considering both quantitative and qualitative evidence, and applying lenses to ensure results are equitable for all people. Important lenses to apply include gender, diversity, age, ability, mental health, class, culture, language and literacy, sexuality and gender identity, and geography.
11. Be monitored, measured, and evaluated.



PEI WORKING GROUP FOR A LIVABLE INCOME

FAQs -- MEDIA TALKING POINTS, APRIL 2021

What is a Basic Income Guarantee?

- A basic income guarantee is a cash payment sent regularly (for example, monthly) to individuals who need it to meet their basic needs and live in dignity.
- Any adult who has less income than they require to meet their needs would be eligible. The payment would go to anyone eligible regardless of their work status.
- The payment comes from government: to work in PEI, basic income guarantee would require support and coordination between provincial and federal government.

What is our goal?

- We want basic income guarantee established as a permanent program that begins with all of PEI and that is designed to be scaled up to all of Canada.
- There are precedents for this kind of program! Medicare began in Saskatchewan and became a national program, and the \$10-a-day childcare began in Quebec and is now being scaled up for all of Canada.

Is a Basic Income Guarantee the same as a Universal Basic Income?

- There are many models for basic income that have been tried in Canadian communities in Manitoba and Ontario and outside Canada in places including Finland, Brazil, India, Kenya, and more.
- **The model we advocate for, after years of consultation with the PEI community, is a basic income guarantee that sets an *income floor* that no one would fall below, so it would eliminate the risk of falling into poverty.**
- Rather than a cheque to everyone of every income level (which would include very rich people), the basic income guarantee *we want* would be available to any adult, but it would be *income-tested*, so a benefit would only go to those who need it to top up the level of their income, no matter the source of their income.
 - The Canada Child Benefit works this way, for example. It gets to all children who need it based on their family's income on their tax return.
 - For seniors, the Guaranteed Income Supplement works like this as well: it goes to anyone 65+ whose income is below a specified level, as indicated on their tax return.
 - Most people want more than the basics. When they know their basic needs can be met, most will find ways to increase their income and quality of life.
 - Above the "income floor," basic income guarantee recipients could earn as much as they wanted from whatever sources they wanted. A percentage of their additional income would be taxed back until their earnings were high enough not to need a basic income top-up anymore.
 - For example, if a person receiving Basic Income Guarantee benefits earned \$1,000 additional dollars, and the reduction rate was 40%, \$400 would be taxed

back. If they continued to earn more income from other sources to be able to meet their needs, their BIG benefit would gradually reduce. If their income went down again below the income floor, they would be eligible for Basic Income Guarantee benefits again. They could keep any savings they put aside from their time of higher income.

- By comparison: Currently, a person on social assistance income support in PEI who earned \$1,000 additional dollars would be allowed to keep just \$250, and if they continued to earn more income from other sources, they would at some point become ineligible for assistance, and their support would be cut off. If their income went down again, they would have to reapply for assistance and prove they met all the eligibility criteria, including having depleted any savings or liquidated their assets first.
- A basic income guarantee would not discriminate on the basis of what kind of work or how much work a person does. It would give value to unpaid and underpaid work and transform our understanding of work.
 - Basic Income Guarantee benefits would be available to people working full-time at low wages or part-time with less than enough income. It would support people with precarious work and people who can only work some of the time because of health or disability. It would support caregivers doing unpaid work and community volunteers, entrepreneurs, and artists alike.
 - The workforce is changing rapidly! Many traditional jobs are being replaced by automation, and that trend will continue. Employment standards and wages and employment supports are not keeping up with the changes.
- The principles of basic income guarantee and the model we support are reflected in the (good, even if imperfect) model the Special Committee on Poverty in PEI presented. All PEI political parties supported their model through their endorsement of the Special Committee report.

What about design of the program? What about X or Y problem in a basic income model that was tried in another location? Will a PEI model be the same as an Ontario model?

- The way a basic income guarantee is designed really matters, and it will take some work to get it right. Any design will need to be tweaked to make sure it meets everyone's needs equitably.
- In PEI we have a good place to start with a basic income guarantee design in the research of the Special Committee on Poverty in PEI.
- We would like grassroots people, especially people living in low income and close to low income, to be involved in the program design and roll-out.
- We believe that in PEI, we have what we need to design a good system and to tweak what needs tweaking. We have strong public support and knowledge of basic income, and strong principles that all political parties have agreed to. Examples of principles:
 - Universal and unconditional to all adults, no matter their work status.
 - Note: In the case of the model we support, "universal" does *not* mean that benefits automatically go to every adult in Canada. It means that every adult in

Canada is universally able to have their income tested to determine if they need a top-up benefit, no matter who they are or where their income comes from.

- Sufficient to provide for people's basic needs. To us, this means enough to pay rent or mortgage and monthly utility bills, to buy nutritious food and medicine, to use transportation, to continue learning, to access childcare or eldercare, and to deal with emergencies.
- Grounded in human rights.
- Based on evidence and continuing research and evaluation to figure out how to continuously improve the program.

What is the biggest benefit of a Basic Income Guarantee?

- In the places that have used a Basic Income Guarantee, the biggest benefit was to people's health. That includes both their physical and mental health.
- Income is the most important social determinant of health. When people do not have enough income, their health suffers.
- Healthcare costs are the biggest expense of governments in Canada. Allowing people to live in poverty costs their health, the health system, and all of us who rely on healthcare.

How much is a Basic Income Guarantee program going to cost?

- PEI has a fully costed model for a basic income guarantee that would take a major step towards eliminating poverty. It looks like a large investment. We think people are worth this investment. We think eliminating poverty and investing in health, wellbeing, and dignity is worthwhile.
- It costs a lot to maintain the current system that keeps people trapped in poverty and puts so many restraints on low-income people that they lose opportunity and hope!
- Poverty costs us all in lost human potential, in the health and wellbeing of ourselves and our family members and our neighbours, in healthcare costs, in justice costs, and in productivity.
- The most recent estimate of the cost of poverty in PEI is over \$272,500,000 which is over 4% of the GDP, and amounts to \$1,810 per person (Canadian Centre for Policy Alternatives, 2021).
- Every budget sets priorities. Often the priority is meeting the needs of the wealthy. We want to see a budget that puts the priority of meeting the needs of the people first, especially people who are living in low income.
- There is enough money to go round in Canada. We believe it is reasonable to tax wealth to pay for programs that eliminate poverty. We need to address extreme wealth as well as poverty!

Why eliminate poverty?

- It is unacceptable to us that anyone in PEI has to live in poverty, without the money they need to meet basic human needs.
- Work by the Special Committee on Poverty in PEI showed that 40% of Islanders could benefit from the basic income guarantee model. That means that 40% of Islanders are already not able to meet basic needs some or all of the time.
- Poverty is a matter of human rights!

- It is in our power in PEI and Canada to eliminate poverty. We just have to make it a priority.

But won't people stop working if they are getting a Basic Income Guarantee?

- No. Basic income projects have been tried in many places, and there was never any evidence of people leaving the workforce, except new parents, especially women, taking longer off work to care for children; and young people, especially young men, staying in school longer.
- When work is available, PEI has the highest attachment to the workforce of anywhere in Canada! People want to work for all kinds of reasons.
- It is true that some employers may have to improve wages, hours, and working conditions to retain workers who have the option to leave unacceptable or unsatisfying workplaces.
- Social assistance is a *real* disincentive to work! Income over a measly \$250 are clawed back dollar for dollar, and recipients have to account for every penny of additional revenue to income support workers who have the power to cut off their benefits!

What is wrong with the way we support people now?

- Income support rates are not and have never been enough to meet people's needs with dignity. People are only eligible after they are destitute. The level of scrutiny people have to agree to in order to receive benefits is undignified. The stigma and shame attached to social assistance are assaults on people's dignity and worth as human beings.
 - The official poverty line for Canada is the Market Basket Measure. This measure tells us how much a basket of basic needs actually costs in every part of PEI: Charlottetown, Summerside, and rural PEI. Social Assistance rates are very, very far from providing enough to fill PEI baskets. The rates are NOT enough money to meet people's basic needs.
 - People with disabilities often have additional costs to meet their basic needs. The AccessAbility program and disability supports also do NOT provide enough income to meet the basic needs of people with disabilities.
- We have a variety of programs in PEI, and each is important to help with one part of what people need, or one group of people: there are Income Support and AccessAbility programs, child care subsidies and rent vouchers for housing, but putting the pieces together is a full-time job for people living in low income.
- The system we have is NOT WORKING. There are still many people in PEI living in low income or hovering so close to the line they experience constant stress.

What about just adding to programs we already have and piecing together a basic income guarantee?

- The Old Age Security and Guaranteed Income Supplement shares a lot in common with a basic income guarantee – except it is not truly enough income to meet people's needs and it is age restricted to people over 65.
- We also have supports for children that are modelled on Basic Income Guarantee, through the Canada Child Benefit.

- When we talk about adding programs, often people talk about adding supports for people with disabilities or programs like CERB, which support people in an emergency situation.
- What we are missing is support for people who are older than children and younger than seniors who our culture says “should” be earning their income from work. But the workforce doesn’t provide enough income or security or support for many, many people. The workforce doesn’t accommodate people for different abilities. Employers don’t support enough sick days or caregiving days.
- We need a universal, unconditional program that supports people regardless of their work status as well as their age and ability.

Wouldn’t it be better to invest in more public supports and public services instead of paying the high cost of a basic income? Won’t a government that puts a basic income in place then fail to invest in childcare or pharmacare or healthcare additions or public transit or other public goods?

- Governments set priorities about public services all the time. Yes, there is a risk governments may invest in basic income guarantee and use that as an excuse not to invest in pharmacare. There is also a risk that governments will invest in neither! Failing to establish an income floor for Islanders and Canadians is no guarantee that there will be increases to other public supports!
- When a Basic Income Guarantee is finally in place, and people across a whole population experience the benefits, individually and collectively, we think it will be a very difficult program to cancel.

How can we ensure that BIG will continue after a change in government?

- It is really important for Basic Income Guarantee to be set up with the intention of it being a permanent program. It is really important for it not to be set up as a pilot. People can’t trust pilot projects because they know they can’t rely on them to continue.
- Here in PEI, it is really important for Basic Income Guarantee to be set up as a whole-province program. It is a lot easier to cancel a program that only affects a small pocket of voters than to cancel a program that affects a whole community.
- If a Basic Income Guarantee is set up as a permanent program that includes the whole province, it will be a lot easier for people to see the benefits and the community to enjoy the rewards – and it will be a lot harder for any government to cancel the program.

Is there an assurance that EI will continue?

- The EI program is an important source of income for many people in PEI. The system is also important because it is a well-established system that everyone who works pays into as an insurance program. The EI program also delivers sick benefits, maternity and parental benefits, and compassionate care benefits that are very important to Canadians.
- It will be up to governments to decide if EI (or any other program) would continue alongside a Basic Income Guarantee, but when Basic Income Guarantee is set up as a program for PEI, it would make sense to continue EI and treat it the same as any other source of income. If people receive enough income through work and EI to meet their basic needs, they would not

be eligible for a Basic Income Guarantee top-up. If they don't receive enough from work and EI, they would be eligible – like anyone else, with any other work status or source of income.

How would the "invisible" people be reached?

- There will be work to do to overcome barriers to reaching everyone who needs Basic Income Guarantee. People who don't file income taxes will need help and support to file income taxes. People who do not live in a home or are not attached to an address will definitely need a Basic Income Guarantee system that eliminates barriers to them receiving benefits.
- There will be opportunities to shift the focus of charitable work in the community if people receive money to meet their basic needs!
 - For example, if your service group usually runs a food drive, but food drives become less urgent in the community, your group could run an income-tax clinic instead!
- Basic Income Guarantee would support a lot of people who do unpaid "invisible" work, including unpaid caregiving, domestic work, and sex work. There is a lot of work that is "invisible" to the economy, and giving that work value will promote the visibility of the people who do that work.

Will there be loss of jobs in social programs departments?

- The PEI Working Group for a Livable Income supports public sector workers and public sector jobs.
- With a Basic Income Guarantee in place, people who work delivering social programs could spend less time enforcing eligibility rules and program policies and monitoring and supervising low-income people's choices. They would have more time for addressing root causes of social problems: inequality, systemic and structural barriers to people based on their gender or race or age or ability, barriers to accessibility and inclusion, mental health issues and addictions, violence and trauma.
- There isn't a lot of evidence that Basic Income Guarantee would save money in public administration. In our view, cutting public sector jobs would be a *bad reason* to implement Basic Income Guarantee. The reason for implementing Basic Income Guarantee should always be to value people, to support human rights, to reduce suffering, to increase health and dignity, and to eliminate poverty.

What will it take to transition from the concept that Basic Income Guarantee is just another assistance program?

- Basic Income Guarantee would completely replace some assistance programs, such as income support, and it would transform the social assistance system.
- Right now, most people seem to accept the concept of the Canada Child Benefit and the Old Age Security/Guaranteed Income Supplement system. They don't think of these as "just another assistance program." PEI people and Canadians accept basic-income-style programs for children and seniors – and these programs have succeeded in reducing poverty in these groups!

- Like a Canada Child Benefit or the OAS/GIS, a basic income guarantee would make it normal to receive and expect assistance to meet basic needs out of the tremendous plenty of PEI and Canada.
- We have to transform our attitude about who deserves to have their needs met and who doesn't. The only reason we allow our society to accept "poverty reduction" instead of poverty elimination is that we believe some people deserve to be poor. The only reason we have programs for children and seniors and not for adults is that our society insists that adults' income has to come from work, only certain kinds of work count, and there is a very wide range in how well or poorly people are paid for work.
- A basic income guarantee starts from the premise that *everyone* is worthy. Everyone has value. Everyone contributes to the fabric of society just by their existence and their humanity. Everyone deserves to live in health and dignity and to get their needs met.

Is there room for provinces and territories the design BIG according to their need?

- Governments will have to sort out some big questions about the design of Basic Income Guarantee. We believe they should do that with input from the grassroots and the communities and people that will be affected.
- *Everyone* is affected when some people among us live in poverty, and so everyone needs to be part of the Basic Income Guarantee solution.
- From what we have heard and learned here in PEI, we think the best chance of a successful Basic Income Guarantee would be designed for PEI and respond to local needs. This could only be done in collaboration with the federal government and with leadership and standards set federally and dedicated funding from the federal government.
- A national program with federal-set standards and support, but with provincial and territorial features specialized for each place, is achievable in Canada, with the political will. We can model it in PEI first!

Can Basic Income Guarantee be designed by Indigenous peoples as a distinctly Indigenous program?

- While we advocate for a program to be set up in PEI that could be scaled to all of Canada, our group would equally support a program designed by Indigenous peoples for Indigenous peoples first. We would still want to see Basic Income Guarantee established as a permanent program (not a pilot), open to a large community or large communities of participants, and scaleable to all of Canada.

How can we keep the connection among the movements: basic income, anti racism, anti ageism, feminism, abilities, and global warming?

- The first step is to put a Basic Income Guarantee program in place built on the intention that it will support equitable outcomes for all people and that it will contribute to a healthy and sustainable environment.
- The design of a Basic Income Guarantee will need to visibly, explicitly reflect equity and inclusion environmental sustainability: the guiding principles are essential!

- The next step will be to engage social movements in monitoring and learning, measuring and providing feedback into the Basic Income Guarantee program, so it continues to improve to meet the goals of equity and inclusion environmental sustainability. Basic Income Guarantee isn't a new idea, and its benefits are proven, but making sure it can grow and continuously improve will rely on research and evaluation – especially research and evaluation that engages social movements!

Summary of Work for Basic Income in PEI
(by Marie Burge)
May 30, 2023

A Proposal for a Guaranteed Basic Income Benefit for Prince Edward Island

PEI Background

Community level **The PEI Working Group for a Livable Income** (WGLI) is a coalition of 10-12 community groups and individuals, established in 2003. It grew out of a community project on minimum wage, from which by resolution of a community forum, we formed a permanent committee which we based on the need for “livable income”, dealing with income from all sources. In our first years we acted as community critic of and contributors to, the PEI government social safety net programs as well as those covered by the Federal government.

For WGLI, livable income means sufficient resources to cover each person’s basic human needs: healthy and culturally appropriate food; safe and affordable housing; safe and affordable transportation; required medications; dental care; access to child and elder care, continuing education and training; and the support and freedom to participate in their community and to cover inevitable emergencies. Livable income supports people to live in good health and in dignity. It was clear to us from the beginning that this condition could not be achieved by an incrementalist approach. Livable income is a basic and collective human right for all people. ***Basic Income is an essential part of the social safety net, without which the success of the other many elements of the social safety net is severely hampered. So it is not improved healthcare OR basic income. It must be improved programs all around AND basic income.***

Political level After two earlier unanimous votes on various aspects, the PEI Legislative Assembly in 2020 unanimously accepted the report of the Special Committee on Poverty in PEI. A major recommendation of that Committee was that PEI proceed in union with the Federal government to create a province-wide basic income program which would be fully funded (provincial & federal) and would be universally accessible to every Islander who needs it to reach the designated “poverty line”. Please note that over the years WGLI made innumerable fruitful presentations to political party leaders, to party caucuses and to the appropriate government policy makers.

Formation of *Coalition Canada basic income- revenu de base* in November, 2019.

Since its beginning in 2019, Coalition Canada has made PEI basic income a pan-Canadian project and has kept the establishment of basic income in PEI as its main goal. Attention: an impetus for forming the Coalition was the reality of two minority governments (Ottawa and PEI) as well as a strong, active, and vocal community-based group (WGLI). Currently the Coalition has reps from all ten provinces and three territories. Marie Burge represents PEI (WGLI) on that Coalition.

Formation of a Proposal Committee in July, 2021.

Coalition Canada formed an economists-politicians-advocates committee to come up with a **Proposal** to prompt federal-provincial officials to begin conversations toward ***establishing in PEI a basic income demonstration program of 5-7 years duration.***

The **Proposal Committee** was made up of eight well-established economists, all pro-basic-income, but all coming from differing perspectives. As well we had five politicians (3 ex MPs: Liberal, Conservative, and NDP) and two sitting PEI MLAs (PC and Green). Besides there were six of us,

classified as advocates. In all, this involved from 80-100 Zoom meetings (*my estimate* and given that the economists worked separately for months until they could come to their own consensus). Meetings of the full committee were less frequent. We dealt with and revised the **Proposal** an inordinate number of times to get to the final stage at which we now have the final copy called, ***A Proposal for a Guaranteed Basic Income Benefit for Prince Edward Island*** (February, 2023)

The Proposal for a PEI basic income demonstration program originated in PEI at both the community level (the PEI Working Group for a Livable Income) and in the political arena (the four political parties).

PEI Working Group for a Livable Income (WGLI) response to the Proposal. For almost twenty years our group developed our expectations of what an ideal basic income program on PEI should look like. We have always known that our model of basic income would be very costly (though well worth the cost). The **Proposal** certainly does not come up to our ideals, partly because it is written not as aspirational, but as an economic document designed to show both levels of government that a basic income program is economically feasible. It is meant to open up the conversation between the Provincial Government and Federal Government and to avoid them walking away from the table, because of high-cost shocks, before they even begin to talk.

If a PEI basic income demonstration program is initiated according to the **Proposal**, we in WGLI will have our work cut out for us in the coming years to ensure that, by right, not one person in PEI is left below the accepted “poverty line”. That’s what social justice advocates do.

Meanwhile, WGLI is opting to accept the **Proposal** as is, as a credible vehicle of getting the governments to the table. It is important that this is “A” **Proposal** not “The” **Proposal**. It is not meant to be a model for implementation. That is the future work of governments and their policy analysts.

Briefings. The group of advocates from the Proposal Committee, by request, have done some briefings on the **Proposal** for advocacy groups (the Green Party of PEI, the PEI Working Group for a Livable Income, Coalition Canada, the Leader of NDP PEI and available election candidates).

- The copy of the embargoed **Proposal** now in the hands of some groups is final, having been accepted by consensus decision of the large pan-Canadian team of advocates, politicians and economists and a number of provincial and federal members of the Civil Service who worked on it for 18 months. At this stage they are not seeking input or tweaking.
- The document is really an economic “take” and basically is not aspirational.
- The briefing is designed to clarify the economic logic behind many aspects of the **Proposal**.
- The principal goal of the **Proposal** is to show the Province and the Federal Government that a basic income demonstration is possible for PEI and to urge the two jurisdictions to begin their conversations about how to move forward on it.

Th releasing the **Proposal** to the general public is the responsibility of the new provincial government.

During the election campaign all party leaders supported basic income for PEI. Premier Dennis King’s position: “I am a big proponent of basic income guarantee”. He said he was “proud” to hand-deliver the embargoed Coalition Canada **Proposal** to the Prime Minister. He said he thinks it is important and that PEI could be a wonderful place for a basic income program. He promised: “I will continue to lobby the prime minister and others to do that here in Prince Edward Island because I think we could be the test lab for a lot of things, most importantly basic income.”

PS A happening in the PEI Legislative Assembly on May 25, 2023:

The Honourable Barb Ramsay, Minister of Social Development and Seniors stated:

This Government believes in Basic Income Guarantee. And everyone in this room knows that. But we need the Federal Government to come on board so we can put Basic Income Guarantee in place so that we can eliminate poverty in Prince Edward Island

August 10, 2023

2023-39

2023 Annual Sidewalk Maintenance

Staff recently requested quotations to complete the required sidewalk maintenance for 2023. The work generally includes excavation of existing sidewalks, supply and preparation of shale base material, concrete pouring, asphalt and topsoil reinstatement, and seeding where required. Quotes were requested from two contractors; MacAusland's Excavation Services and Curran and Briggs, with bids being received as follows:

Curran and Briggs Ltd. - \$25,900.00 plus HST

MacAusland's Excavation Services - \$13,500.00 plus HST

The areas identified for maintenance are as follows:

- Approx. 21 feet along Pleasant Street (3 sections)
- Approx. 93 feet along Woodleigh Drive (2 sections)
- Approx. 32 feet along School Street (3 sections)
- Approx. 1 sidewalk block on the corner of Broadway Street N. & School Street
- Approx. 8 feet along Victoria Street (Barrett's Cross/Robin's Drive Thru Exit)
- Approx. 2 sidewalk blocks on the corner of Garden Drive & Lowther Street

It is recommended that Town Council award the 2023 Sidewalk Maintenance Contract to MacAusland's Excavation Services as per their quote dated August 1, 2023, in the amount of \$13,500.00 plus HST.

- Will allow for a smoother walking surface for pedestrians.
- Will reduce the number of tripping hazards on the Town's sidewalks.
- Will allow for more efficient and safer sidewalk maintenance.

- None noted.

The Town's 2023 budget for sidewalk maintenance as approved by Town Council is \$36,000.00. Based on the quotes received, the lowest bidder was \$13,500.00 plus HST (\$15,525.00).

1. Award the contract, as recommended.
2. Not proceed with the project.
3. Refer the matter back to staff for further direction and deliberation.

\$13,500.00 plus HST

2023/24 Operational Funds

It is recommended that Town Council consider and adopt the following resolution:

BE IT RESOLVED THAT Town Council award a contract to MacAusland's Excavation Services for the Town's Annual 2023 Sidewalk Maintenance as per their quote dated August 1, 2023 in the amount of \$13,500 plus HST.

MacAusland's Excavation Services
 854 Irishtown Road
 Kensington PE C0B 1M0
 macauslandsexcavation@gmail.com
 GST/HST Registration No.: 728980939



Estimate

ADDRESS

doug town of kensington

ESTIMATE # 1013

DATE 01/08/2023

DATE	ACTIVITY	DESCRIPTION	TAX	QTY	RATE	AMOUNT
	Excavation/concrete	replacement of concrete sidewalk blocks that was shown in site view	HST	1	13,500.00	13,500.00
SUBTOTAL						13,500.00
GST/HST @ 15%						2,025.00
TOTAL						\$15,525.00

TAX SUMMARY

	RATE	TAX	NET
GST/HST @ 15%		2,025.00	13,500.00

Accepted By

Accepted Date

-
-
-
-

Aug 8, 2023

Credit Union Centre
Att: Robert Wood
Kensington, PE
C0B 1M0

Dear Robert:

We are currently looking to host a Co-Ed softball tournament in Kensington September 15-17, to help raise money for the Kensington Area Minor Hockey Association. As we discussed we would like to request that the town wave the field rental fees for this event, to ensure we can raise as much money as possible for minor hockey.

Please feel free to contact me at (902) 314-0380 if you have any questions.

Sincerely,
Pat Kelly



Thank you for the crosswalks

Sharon Stewart <sstewartsj@hotmail.com>

Thu 7/20/2023 9:35 PM

To:mail@kensington.ca <mail@kensington.ca>

 1 attachments (4 MB)

received_232361519723121.jpeg;

Good morning, I just want to say a great big. Thank you for putting in the 2 crosswalks. We walk the trails many times a day...and sometimes it would get a little dicey looking out from behind car's on Broadway to cross. And also on Victoria, especially with the flashing lights at the crosswalk so card will hopefully slow down and notice you. Once again a big thank you for this undertaking. We greatly appreciate it. Kindest regards, Sharon, John Denver and Norma Jean 🐾 🐾.



KENSINGTON INDUSTRIAL PARK
1. 10000 S. 100th ST. (10000 S. 100th St.)
2. 10000 S. 100th St. (10000 S. 100th St.)
3. 10000 S. 100th St. (10000 S. 100th St.)
4. 10000 S. 100th St. (10000 S. 100th St.)
5. 10000 S. 100th St. (10000 S. 100th St.)
6. 10000 S. 100th St. (10000 S. 100th St.)
7. 10000 S. 100th St. (10000 S. 100th St.)
8. 10000 S. 100th St. (10000 S. 100th St.)
9. 10000 S. 100th St. (10000 S. 100th St.)
10. 10000 S. 100th St. (10000 S. 100th St.)
11. 10000 S. 100th St. (10000 S. 100th St.)
12. 10000 S. 100th St. (10000 S. 100th St.)
13. 10000 S. 100th St. (10000 S. 100th St.)
14. 10000 S. 100th St. (10000 S. 100th St.)
15. 10000 S. 100th St. (10000 S. 100th St.)
16. 10000 S. 100th St. (10000 S. 100th St.)
17. 10000 S. 100th St. (10000 S. 100th St.)
18. 10000 S. 100th St. (10000 S. 100th St.)
19. 10000 S. 100th St. (10000 S. 100th St.)
20. 10000 S. 100th St. (10000 S. 100th St.)
21. 10000 S. 100th St. (10000 S. 100th St.)
22. 10000 S. 100th St. (10000 S. 100th St.)
23. 10000 S. 100th St. (10000 S. 100th St.)
24. 10000 S. 100th St. (10000 S. 100th St.)
25. 10000 S. 100th St. (10000 S. 100th St.)
26. 10000 S. 100th St. (10000 S. 100th St.)
27. 10000 S. 100th St. (10000 S. 100th St.)
28. 10000 S. 100th St. (10000 S. 100th St.)
29. 10000 S. 100th St. (10000 S. 100th St.)
30. 10000 S. 100th St. (10000 S. 100th St.)
31. 10000 S. 100th St. (10000 S. 100th St.)
32. 10000 S. 100th St. (10000 S. 100th St.)
33. 10000 S. 100th St. (10000 S. 100th St.)
34. 10000 S. 100th St. (10000 S. 100th St.)
35. 10000 S. 100th St. (10000 S. 100th St.)
36. 10000 S. 100th St. (10000 S. 100th St.)
37. 10000 S. 100th St. (10000 S. 100th St.)
38. 10000 S. 100th St. (10000 S. 100th St.)
39. 10000 S. 100th St. (10000 S. 100th St.)
40. 10000 S. 100th St. (10000 S. 100th St.)
41. 10000 S. 100th St. (10000 S. 100th St.)
42. 10000 S. 100th St. (10000 S. 100th St.)
43. 10000 S. 100th St. (10000 S. 100th St.)
44. 10000 S. 100th St. (10000 S. 100th St.)
45. 10000 S. 100th St. (10000 S. 100th St.)
46. 10000 S. 100th St. (10000 S. 100th St.)
47. 10000 S. 100th St. (10000 S. 100th St.)
48. 10000 S. 100th St. (10000 S. 100th St.)
49. 10000 S. 100th St. (10000 S. 100th St.)
50. 10000 S. 100th St. (10000 S. 100th St.)
51. 10000 S. 100th St. (10000 S. 100th St.)
52. 10000 S. 100th St. (10000 S. 100th St.)
53. 10000 S. 100th St. (10000 S. 100th St.)
54. 10000 S. 100th St. (10000 S. 100th St.)
55. 10000 S. 100th St. (10000 S. 100th St.)
56. 10000 S. 100th St. (10000 S. 100th St.)
57. 10000 S. 100th St. (10000 S. 100th St.)
58. 10000 S. 100th St. (10000 S. 100th St.)
59. 10000 S. 100th St. (10000 S. 100th St.)
60. 10000 S. 100th St. (10000 S. 100th St.)
61. 10000 S. 100th St. (10000 S. 100th St.)
62. 10000 S. 100th St. (10000 S. 100th St.)
63. 10000 S. 100th St. (10000 S. 100th St.)
64. 10000 S. 100th St. (10000 S. 100th St.)
65. 10000 S. 100th St. (10000 S. 100th St.)
66. 10000 S. 100th St. (10000 S. 100th St.)
67. 10000 S. 100th St. (10000 S. 100th St.)
68. 10000 S. 100th St. (10000 S. 100th St.)
69. 10000 S. 100th St. (10000 S. 100th St.)
70. 10000 S. 100th St. (10000 S. 100th St.)
71. 10000 S. 100th St. (10000 S. 100th St.)
72. 10000 S. 100th St. (10000 S. 100th St.)
73. 10000 S. 100th St. (10000 S. 100th St.)
74. 10000 S. 100th St. (10000 S. 100th St.)
75. 10000 S. 100th St. (10000 S. 100th St.)
76. 10000 S. 100th St. (10000 S. 100th St.)
77. 10000 S. 100th St. (10000 S. 100th St.)
78. 10000 S. 100th St. (10000 S. 100th St.)
79. 10000 S. 100th St. (10000 S. 100th St.)
80. 10000 S. 100th St. (10000 S. 100th St.)
81. 10000 S. 100th St. (10000 S. 100th St.)
82. 10000 S. 100th St. (10000 S. 100th St.)
83. 10000 S. 100th St. (10000 S. 100th St.)
84. 10000 S. 100th St. (10000 S. 100th St.)
85. 10000 S. 100th St. (10000 S. 100th St.)
86. 10000 S. 100th St. (10000 S. 100th St.)
87. 10000 S. 100th St. (10000 S. 100th St.)
88. 10000 S. 100th St. (10000 S. 100th St.)
89. 10000 S. 100th St. (10000 S. 100th St.)
90. 10000 S. 100th St. (10000 S. 100th St.)
91. 10000 S. 100th St. (10000 S. 100th St.)
92. 10000 S. 100th St. (10000 S. 100th St.)
93. 10000 S. 100th St. (10000 S. 100th St.)
94. 10000 S. 100th St. (10000 S. 100th St.)
95. 10000 S. 100th St. (10000 S. 100th St.)
96. 10000 S. 100th St. (10000 S. 100th St.)
97. 10000 S. 100th St. (10000 S. 100th St.)
98. 10000 S. 100th St. (10000 S. 100th St.)
99. 10000 S. 100th St. (10000 S. 100th St.)
100. 10000 S. 100th St. (10000 S. 100th St.)

Re: Kim's contact

Elizabeth Hubley <libhubley@gmail.com>

Wed 8/9/2023 9:34 AM

To: kcaseley@kensington.ca <kcaseley@kensington.ca>

Cc: cao@kensington.ca <cao@kensington.ca>

Thank you for the information. Hi Kim - firstly I will explore the possibility of a duplex on the property, so going to Town Council would be my first step. I will follow up with a surveyor. tks li

On Mon, Aug 7, 2023 at 3:00 PM kcaseley@kensington.ca <kcaseley@kensington.ca> wrote:

Thanks, Libbe

As discussed last week, your property is currently zoned R1 (Single Residential Zone). In order to move forward with the proposed construction of a duplex, the property requires an R2 - Low-Density Residential Zoning designation.

Our initial step is to have Town Council approve staff to forward your application to our planning consultant for review and recommendation back to the Town. Your request *could* be brought to Town Council this coming Monday, August 14 for consideration, and with their approval, we will forward it to our planning consultant (Hope Parnham).

Following Hope's review and confirmation that your proposal is supported by the Development Control Bylaw, we will then move forward with the scheduling of a Public Meeting for re-zoning. As you are looking to subdivide the property, I would suggest speaking with a land surveyor to discuss having the land surveyed as a subdivision plan will also be required.

If you are looking at the possibility of a Solar Energy field, we will hold off on the duplex development and can further evaluate the feasibility of a solar project.

Please let me know how you would like me to proceed. If you have any questions, please feel free to give me a call or stop in.

Cheers,
Kim

From: Elizabeth Hubley <libhubley@gmail.com>

Sent: Monday, August 7, 2023 9:36 AM

To: kcaseley@kensington.ca <kcaseley@kensington.ca>

Subject: Re: Kim's contact

Thank you Kim. I'm inquiring about an option to subdivide my property on Victoria St. to build a two unit duplex seniors housing unit. I have questions about how best to divide the property, frontal issues, water, sewer, and electricity, and compatibility with neighbourhood. Your assistance is helpful. I have also thought of a solar energy field. tks lib

Over 30 trucks!
Facepainting!
Food!
Family Fun!
Entertainment!
Music!
Miniature Golf!
Contests!



Sunday
Sept 24, 2023
from 1:00-4:00 p.m.
at Kool Breeze
Farms, 231 Read Dr,
Summerside



2023 PEI Touch a Truck

Fun for the whole family! Trucks, trucks and more trucks!
Face painting, food, entertainment and more!

When: Sunday, September 24, 2023

Time: 1:00 p.m. to 4:00 p.m.

Where: Kool Breeze Farms, 231 Read Corner, Summerside

How Much: \$5.00 per person



Touch a Truck
Website



Family Place
Website

For more information, register your vehicle or to enquire about sponsorship opportunities:

Email: fp@familyplacepei.com

Phone: 902-436-1348





We must raise \$680,595 by September 8th to meet our 2023 Drive to Save Lives Campaign goal. **With the deadline only weeks away, we must hear from you today!**

August 2023

Town Of Kensington
Po Box 418
Kensington PE C0B 1M0

Dear Friends,

Thanks to donors like you, remarkable progress has been made in our fight to beat heart disease and stroke. But we still face new obstacles and challenges. The need for life-saving support has never been greater.

Today, more than 3.5 million people across the country of all ages, ethnicities and genders are living with heart disease, stroke and vascular cognitive impairment.

That's why we must act now to beat heart disease and stroke.

As I write to you, we have reached 49% of our 2023 Drive to Save Lives fundraising goal. Our progress so far is a direct result of the generosity and dedication of supporters like you – *thank you!*

However, we have so much more work to do!

Right now, the situation in Prince Edward Island and all across Canada is urgent. The need for support has never been greater. Based on our findings, the numbers are startling: 750,000 people have heart failure, and 100,000 are diagnosed each year.

Problem: A heart attack can leave the heart muscle damaged and unable to beat properly, leading to heart failure.

Solution: A patch that combines natural collagen and nano-engineering could repair damage and keep the heart beating.

Heart & Stroke funded researcher Dr. Emilio Alarcon compares his research to decorating a birthday cake with a handful of tiny sprinkles. In this case the sprinkles are metal nanoparticles that conduct electricity, and the cake is fibre engineered from naturally occurring collagen. By combining them, his team at the University of Ottawa is developing a new material that mimics heart muscle.

"The hope is that this will help the heart to beat," repairing damage caused by a heart attack and preventing heart failure, he says.

"We will create an implantable patch which would degrade as natural cells grow around it, ultimately blending with the heart to produce a bio-synthetic muscle."

(over please)

Heart & Stroke

Toll Free: 1-877-882-2582 • Email: donorinfo@heartandstroke.ca

CAN-1

None of this would be possible without donors like YOU. "Heart & Stroke has the vision to fund things that are innovative," says Dr. Alarcon.

Your support helps beat the sudden devastation that too many of us experience. Your consistent generosity and dedication funds world-class research that saves lives.

Your generous donation today of \$50, \$75 or even \$100 will help researchers like Dr. Alarcon. Will you help us reach our 2023 Drive to Save Lives Annual Campaign goal of \$1,334,500 by September 8th?

Dr. Alarcon is one of over 400 researchers and research teams in hospitals, universities and research institutions across Canada who need our support to make the next big breakthrough. More can be done – *more must be done* – to support the expertise and vision of these brilliant medical minds.

Please give generously and help accelerate medical breakthroughs that only research can achieve.

When we beat as one, we achieve so much more together.

Thank you for your continued support.

Sincerely,



Avril Goffredo
Executive Vice President, Fundraising and Marketing
Heart and Stroke Foundation

P.S. Please respond by September 8th with your most generous donation to the 2023 Drive to Save Lives Annual Campaign.



Your donations fund the research breakthroughs that save lives.

Your support of the 2023 Drive to Save Lives Annual Campaign is critical. Please give.

The vital Drive to Save Lives Annual Campaign has only reached 49% of its goal

Campaign Results

2023 Drive to Save Lives Launch Date: January 13, 2023
Campaign Deadline: September 8, 2023

2023 Drive to Save Lives Goal: \$ 1,334,500
Donations received as of August 1, 2023: \$ 653,905

Balance needed by September 8, 2023: \$ 680,595
Balance Needed in Eastern Canada: \$ 41,645

Percentage of Goal Achieved: 49%
Percentage of Goal Remaining: 51%

Please donate today to make sure that 100% of research projects are fully funded.

Please detach here ▼

YES! I'll support the Annual Campaign with my best gift of:

\$100 \$75 \$50 Other \$ _____

Many donors in Kensington like to give this amount!

I have enclosed my cheque, payable to **Heart and Stroke Foundation**
 Please charge my gift to: VISA MasterCard AMERICAN EXPRESS

CARD # _____ EXPIRY _____

SIGNATURE _____

www.heartandstroke.ca/donors
1-877-882-2582

Toll Free: 1-877-882-2582
Email: donorinfo@heartandstroke.ca
Charitable Registration Number
10684-6942 RR0001



Town Of Kensington
Po Box 418
Kensington PE C0B 1M0

Receipts will be sent via email

EMAIL _____

- I have included Heart & Stroke in my Will.
- Please send me information about making a gift in my Will.
- Please do not share my name with other organizations.
- I would like a receipt for gifts under \$20 (Enter email above).

8-13308999

432 136 004 5277 24-H1NZDMP-AGAA0-V1

Join our Monthly Giving Program

041770

24-H1-RD-EN

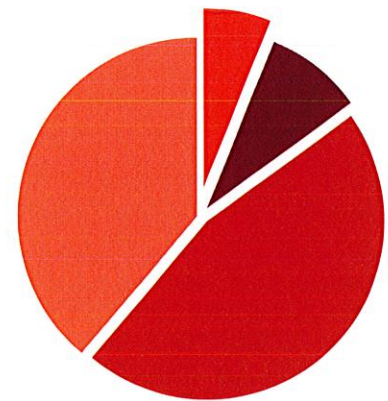

Balance Needed by Region

- \$41,645 Eastern Canada
- \$59,750 Quebec
- \$302,350 Ontario
- \$276,850 Western Canada

July 18, 2023

Mayor and Council, Town of Kensington.

I am requesting the Town of Kensington consider approving the placement of a "Locks of Love" artwork heart in the vicinity of the Alysha Toombs Park.

The artwork will be made by Malpeque Fine Iron. It is described as being in the shape of a heart, 6 feet high x 4 feet wide with mesh in it to put locks on. The plan is to have it Red in colour finished on the bottom to suit the location it is installed. It will be made of 2x1 iron tubing which is long lasting.

The estimated cost is expected to be around \$3,000 including HST. I have attached a picture of the artwork provided by Malpeque Fine Iron so you have an idea of what it would look like.

I am requesting the Town of Kensington consider the following.

1. Approval to locate the artwork in the area of the Alysha Toombs Park. The exact location to be determined in consultation with Town Staff.
2. Approval of a development permit (if required) and the cost of the development permit to be absorbed by the Town of Kensington.
3. Cover the total cost of the artwork which is estimated to be around \$3,000. If not the total cost, then a donation to the project.

I have attached a write up which clarifies the purpose of the artwork called "Locks of Love".

Respectfully;

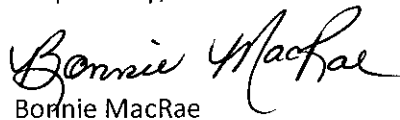
Bonnie MacRae

Attached:

1. Picture of Artwork
2. Description of project
3. Map with potential location of the artwork highlighted

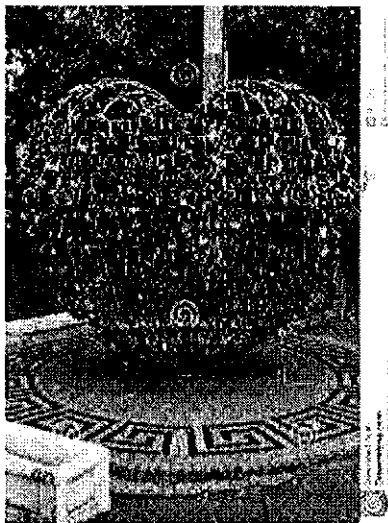

There is a group of individuals in Kensington that are passionate about a project that has been discussed for many years. There is a memorial Park in the Town of Kensington near the Credit Union Centre Rink, the Alysha Toombs Memorial Park. The group feel that an addition of a heart shape "Locks of Love" would make a great addition to this park. Everyone has lost a loved one that is special to them, they can bring a lock and put it on the heart shape that has mesh wire for them to lock onto in memory of that loved one.

There is a similar design in Charlottetown that is very popular on the waterfront. We would like to do a similar installation but just a heart shape instead of the word LOVE.

There is a great deal of interest and support in this project and we feel that it would be a very special place for community members to spend time at the park and place their lock on the heart.

Once the heart was installed, we would be planning a revealing ceremony and would be inviting and highlighting any contributors at that time.

Thank you for your consideration, please contact me if you have any further questions.

Bonnie MacRae



Imagery ©2023 Airbus, CNES / Airbus, Maxar Technologies, Map data ©2023 20 m

Potential Area

To: Town of Kensington

For: Town of Kensington Education Scholarship

It was an honor to have received this award. I greatly appreciate your support in my education and for seeing something in me. These funds help relieve the financial stress of University.

I can now focus more on what I want to do to achieve my dreams. Thank you so much, I will not let you down.

Sincerely,

Bjorn Schmidt

June 29, 2023



Transportation
and Infrastructure

Transports
et Infrastructure



Office of the Minister
PO Box 2000, Charlottetown
Prince Edward Island
Canada C1A 7N8

Bureau du ministre
C.P. 2000, Charlottetown
Île-du-Prince-Édouard
Canada C1A 7N8

June 30, 2023

Town of Kensington
Mayor Rowan Caseley
PO Box 418
Kensington, PE COB 1M0

Rowan

Dear Mayor Caseley:

Thank you for your letter, on behalf of the Kensington Town Council, expressing support for the use of ATV's on select portions of provincial roads in and around your community.

The province is reviewing possible legislative changes to the Highway Traffic Act that would allow ATV's to operate on public roads.

Thanks again for sharing your show of support to the PEI ATV Federations request.

Sincerely,

Ernie Hudson

Ernie Hudson
Minister

Women are stronger together: Join us and make a lasting impact

Learn more about our important work.



Canadian
Red Cross

Tiffany
Circle

A SOCIETY OF WOMEN LEADERS

The Tiffany Circle is a group of extraordinary women from across Canada whose goal is to improve the lives of those in need by supporting the Canadian Red Cross.

Using their time, talent and financial resources, the Tiffany Circle has an innovative approach to expanding the capacity of the Canadian Red Cross to bring humanitarian aid to those in need. This circle of dynamic women share a sense of core humanitarian values and becoming a member is your opportunity to participate in and strengthen an incredible community.

“I didn’t know that joining the Tiffany Circle would provide an opportunity to participate actively and that, in my own way, I too could carry the respected title of being a Red Cross volunteer.”

– Tiffany Circle Member

IN THEIR COMMUNITIES AND AROUND THE WORLD

These women follow in the footsteps of a long line of women leaders who have supported some of the most vital Red Cross services. Over the past couple of years, Tiffany Circle members have supported crucial Canadian Red Cross work at home and internationally. This includes responses to Hurricane Fiona in Atlantic Canada and eastern Quebec, various Indigenous programs across Canada, and around the world after earthquakes in Türkiye and Syria, flooding in Pakistan and conflict in Ukraine.



Supporting people in need during times of emergency and conflict.



Delivering lifesaving medicines to support maternal, newborn and child health.



Building healthy and safe communities through training and education.

A WORLD OF MEANINGFUL OPPORTUNITIES

Through a variety of rich volunteer, educational and social opportunities, Tiffany Circle members share the story of the Red Cross. They belong to a powerful network of women around the world.

As a Tiffany Circle member, you will stand proudly with an inspiring group of women committed to ensuring the Canadian Red Cross will always be there when people are in need of a place to turn. Learn more about this important work and see if the Tiffany Circle is right for you.



A Red Cross Red Crescent Movement volunteer hands out food to survivors after a devastating earthquake impacted Türkiye and Syria. Credit: Turkish Red Crescent

For more information, please reach out by email:
TiffanyCircle@redcross.ca



**Canadian
Red Cross**

**Tiffany
Circle**



86561LRC1-A

U77473

Proud supporter of the Canadian Red Cross.

Town Of Kensington
55 Victoria St
Kensington, PE C0B 1M0

**Every dollar donated to
the Canadian Red Cross
Before July 27th could be
worth triple!***

Dear Friend,

I hope this letter finds you well.

I am writing you today on behalf of the thousands upon thousands of people affected by emergencies in Canada and around the world, including Hurricane Fiona that affected Atlantic Canada and eastern Quebec, the earthquake that devastated Türkiye and Syria, and the ongoing armed conflict in Ukraine. These people depend on the hope and inspiration that you provide through your support of the Canadian Red Cross.

Your generous support in the past has allowed the Canadian Red Cross to reach out to those in need. And today, we are thrilled to share an extraordinary opportunity that could *triple the impact of your contribution.

The Red Cross Tiffany Circle, a growing movement of women leading the way in philanthropy, have come together with a special offer to make every dollar donated between now and July 27th worth *triple by contributing two dollars for every dollar our donors contribute. *(this offer only applies up to a maximum of \$252,500 in total donations).

Take a look at the Triple Gift vouchers I've enclosed and decide how you'd like to make your gift have a *triple impact. But hurry, this extraordinary opportunity will expire on July 27th!

Just think, if you send your donation for \$25, the total gift to the Canadian Red Cross could be \$75.

Or if you send a donation of \$50, that could mean \$150 to help people in need!* You can use the blank voucher to choose your own gift amount. Simply send it back with your donation.

(over, please)

* The Members of the Tiffany Circle will match public individual donations to this campaign up to a maximum of \$252,500. All donations given after this match is fulfilled will be used where needed most.

PLEASE RETURN A MATCHING GIFT VOUCHER ALONG WITH YOUR OWN DONATION AND THIS FORM BELOW TO THE CANADIAN RED CROSS IN THE ENVELOPE PROVIDED.

The Red Cross is there for Canadians during weather-related emergencies, like forest fires and floods, but we're also there for other emergencies such as food insecurity or the crisis we face in mental health. No matter what the response, the Canadian Red Cross works to ensure that those affected receive the help they need.

The Canadian Red Cross is also active internationally—from floods in Pakistan, earthquakes in Türkiye and Syria, and the armed conflict in Ukraine—we provided relief supplies, humanitarian specialists, healthcare, shelter, and other forms of aid to help those in desperate need.

The women of the Tiffany Circle share a deep commitment to helping people and communities by investing in the humanitarian work of the Canadian Red Cross. As philanthropists, community connectors and business leaders, the Tiffany Circle is improving the lives of many – locally, nationally and around the globe.

Together, we can help strengthen the resilience of individuals and communities in Canada and around the world during times of need. The Red Cross provides a wide range of assistance to millions of people in Canada and around the world.

I know how important the Canadian Red Cross' work is to you. Through your generosity, you have helped to create hope and turn it into real progress by providing the resources to help fellow Canadians and people across many borders.

That's why your participation in the *Triple Gift Offer for 2023 is so important – and is especially important this year as we continue to meet the needs of people in Canada and around the world. Every year, our trained staff and volunteers assist thousands of people affected by emergencies – from a fire in a single-family home, to forest fires, armed conflicts or earthquakes that disrupt entire communities. Our humanitarian specialists, such as doctors, nurses, and mental health workers, are at the forefront of many of the world's worst humanitarian crises.

I hope you take advantage of this opportunity by sending your own gift today to help us make the most of the extraordinary offer from the Tiffany Circle! Please send your donation along with one of the enclosed vouchers by July 27th!

Somewhere this year, the Canadian Red Cross will again be called to respond to a crisis. Will we be ready? Absolutely. We'll be able to help because we know we can count on supporters like you. Thank you again for the hope and inspiration you provide.

Sincerely,



Conrad Sauvé
President and CEO

P.S. This year, as we continue to face unprecedented natural disasters and other emergencies, the Canadian Red Cross is helping people in need in many ways. I hope I can count on you so that no one is left alone in their time of need. Remember, send your gift by July 27th, and your support could be worth triple*. Thank you!



**Canadian
Red Cross**

National Office
Suite 8000, 400 Cooper St.
Ottawa, ON K2P 2H8

Activity Statement Through March 31, 2023

Thank you for your generosity!

Statement of Giving Prepared Specifically for

Town Of Kensington

Date	Fund	Amount	Year to Date Total
2023			
History		Totals	
2022		\$2,000.00	
2021		\$0.00	
2020		\$0.00	
2019		\$0.00	

A dark blue textured card with a gold geometric pattern. The pattern consists of a square border with two diagonal lines crossing at the center, forming four triangles. The text "THANK YOU" is centered in a gold, serif font.

THANK YOU

Dear Town of Kensington

I am writing to let you know how grateful I am for your generosity. Because of your support I am going to be able to accomplish so many goals in my life starting with my tertiary education.

No amount of words can express my gratitude but I would like to say thank you.

Yours Thankfully
Sulobe Love



THANK YOU



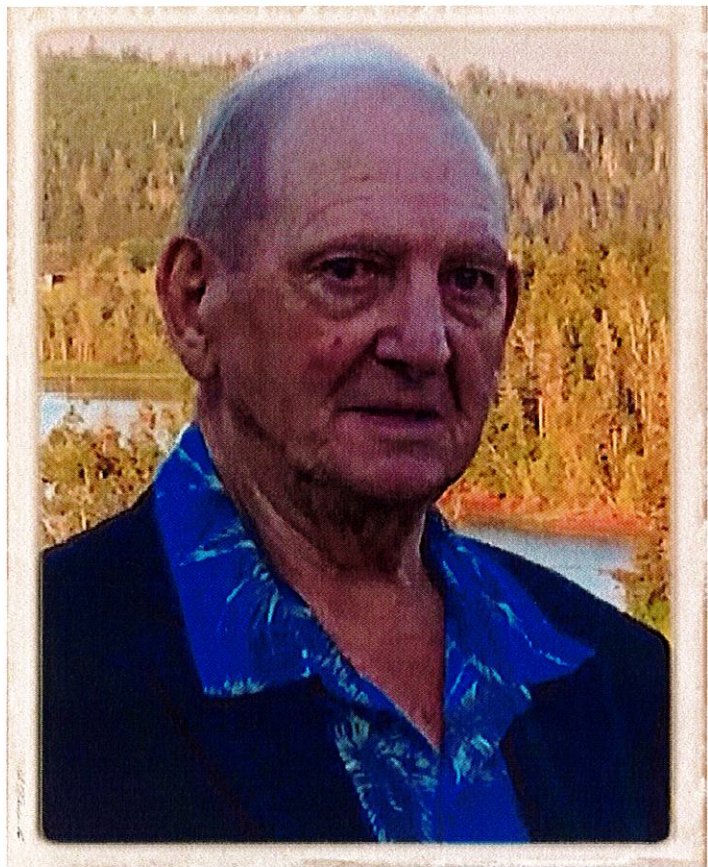

Town of Kensington,
Thank you for
your words of sympathy,
your voice of concern,
your gesture of caring
and the love you offer.

Thank you so much for
your donation to the
Church in memory of
dad.

Sincerely,
Claire, Nancy, Kathy,

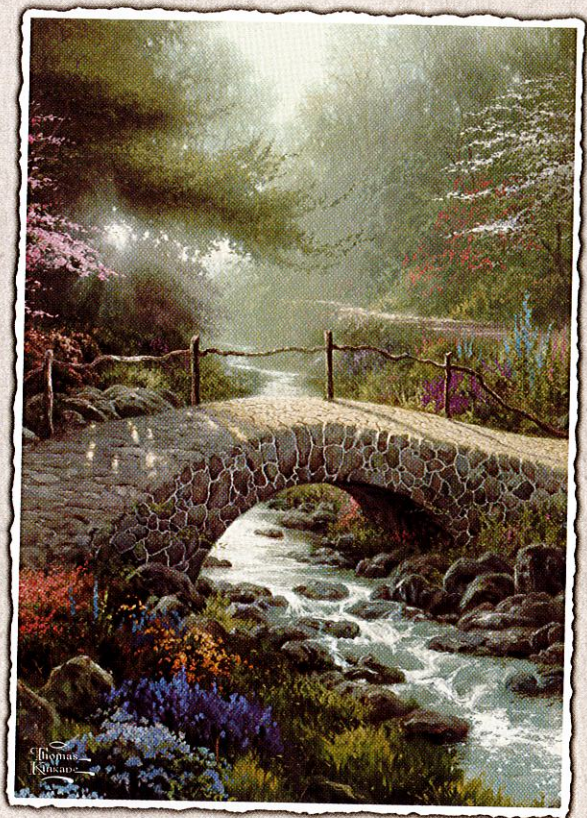

During a time
like this
we realize how much
our friends and relatives
really mean
to us....

Your expression
of sympathy will always
be remembered

*Thanks for donation to St.
Mark's Anglican Church in
memory of Clayton.
Maie, Vernon, Mill and Family.*